

BIM AND DIGITAL TRANSFORMATION INDUSTRY 4.0 TECHNOLOGIES

CONSULTANT AND SERVICES PROVIDER



EXAMPLES OF BIM AND DIGITAL TWIN PROJECTS WATER AND SEWAGE INFRASTRUCTURES

BIM AND DIGITAL TRANSFORMATION CONSULTATION SERVICES

YOUR SUSTAINABLE DIGITAL TRANSFORMATION PARTNER



ABOUT GOLDEN PASS

Situated on the Gulf Coast near Sabine Pass, Texas, Golden Pass LNG is undergoing a historic transformation.

The existing liquefied natural gas terminal is among the largest in the world, and it will soon include liquefaction and export capabilities.

MUSCAT INTERNATIONAL AIRPORT INFRASTRUCTURES WORKS



INFRASTRUCTURES WORKS IN MUSCAT / OMAN (USD 1.8 BILLION)

SUBSURFACE UTILITIES INCLUDING WATER, STORM WATER, IRRIGATION AND SEWAGE NETWORKS

This use case presents an iconic USD 1.8 billion infrastructure project in Muscat, Oman, where BIM and digital transformation delivered substantial value through accurate scope management, enhanced quality control, GIS integration, and the creation of an as-built Digital Twin. It demonstrates how a shared, data-driven single source of truth can optimize the planning and operation of water, stormwater, irrigation, and sewage networks. By leveraging BIM, advanced project controls, and asset digitalization, the project effectively mitigated risks, improved decision-making, and enabled long-term operational efficiency. This initiative goes beyond traditional construction. It represents a strategic investment in smart, sustainable, and resilient water infrastructure, serving as a significant step toward Construction Industry 4.0 and laying a solid foundation for emerging trends such as Digital Twins, Smart Infrastructure, and AI-driven platforms

MUSCAT INTERNATIONAL AIRPORT

SCOPE BIM AND DIGITAL CONSTRUCTION

BIM ADDED VALUE:

- Accurate Scope Management
- Enhanced Quality Control
- Effective Project Controls
- Payment Certificate
- Subcontractor Scope management
- Enhanced Design Coordination
- Interface Management with Other Infrastructure Components, Facilities, or Stakeholders
- Progress Control
- Machine Automation
- GIS Integration
- Data-Driven Decision Making
- Asset Register



MUSCAT INTERNATIONAL AIRPORT - INFRASTRUCTURE WORKS

BIM AUTHORIZING FOR ALL DISCIPLINES

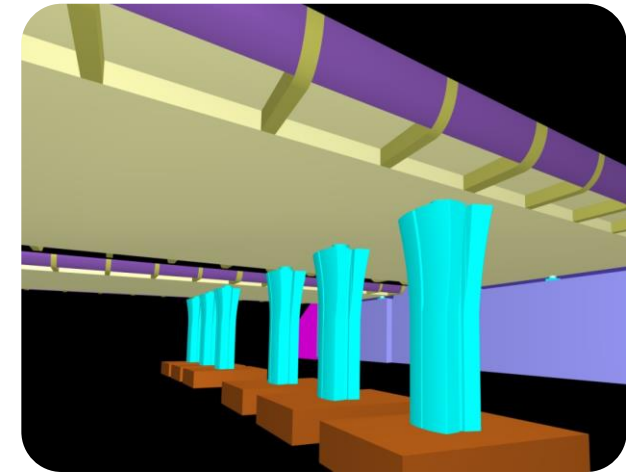
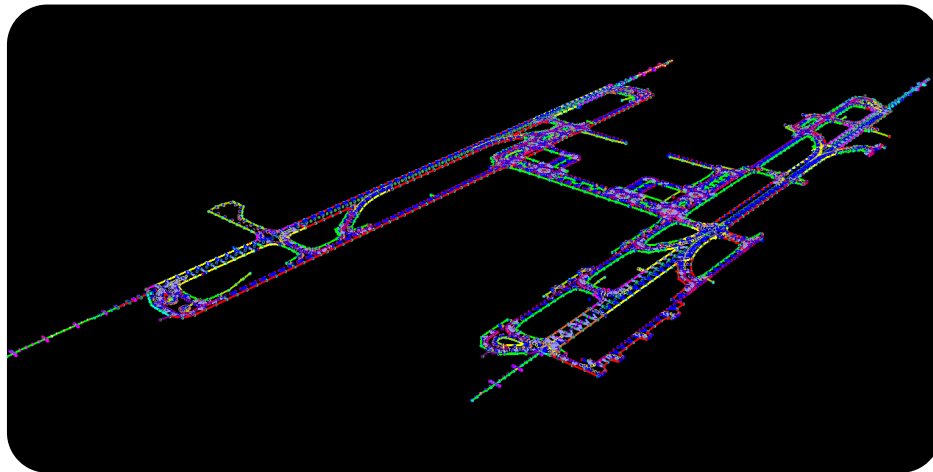
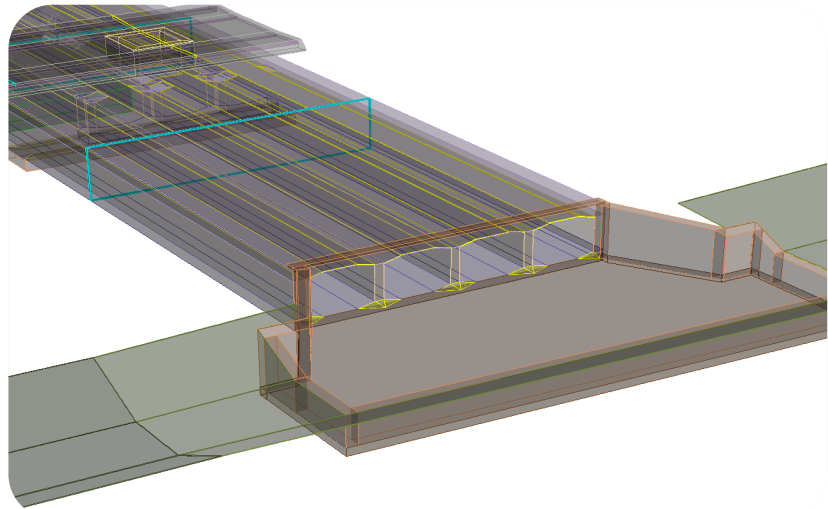
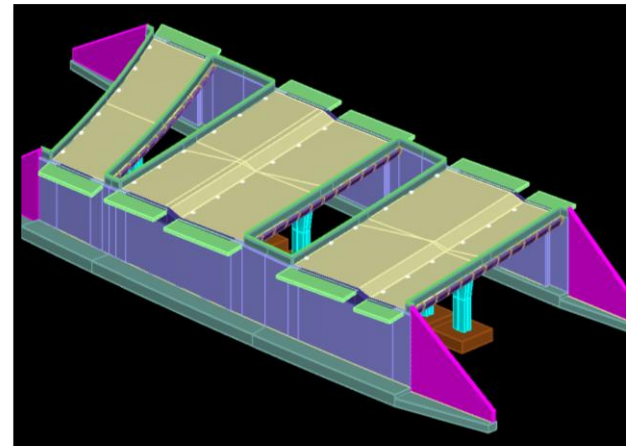
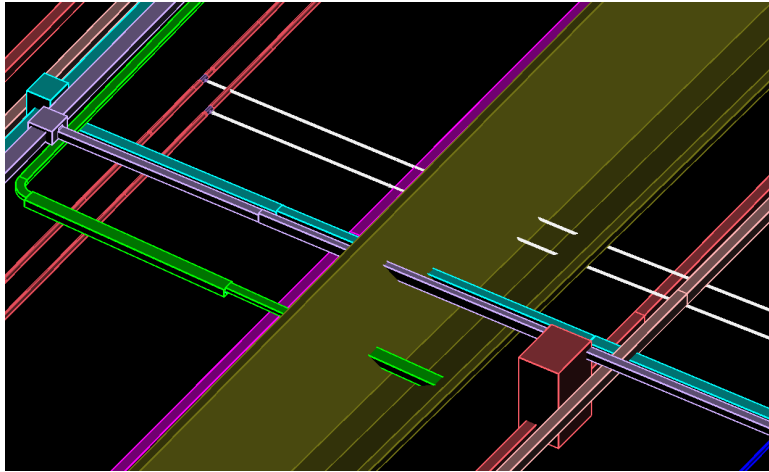
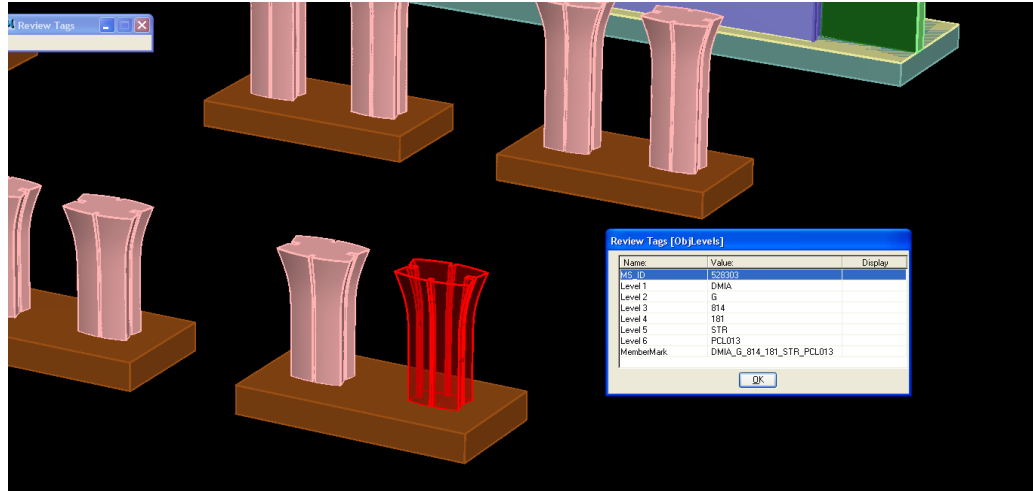

MUSCAT INTERNATIONAL AIRPORT - INFRASTRUCTURE WORKS

BIM AUTHORIZING FOR ALL DISCIPLINES

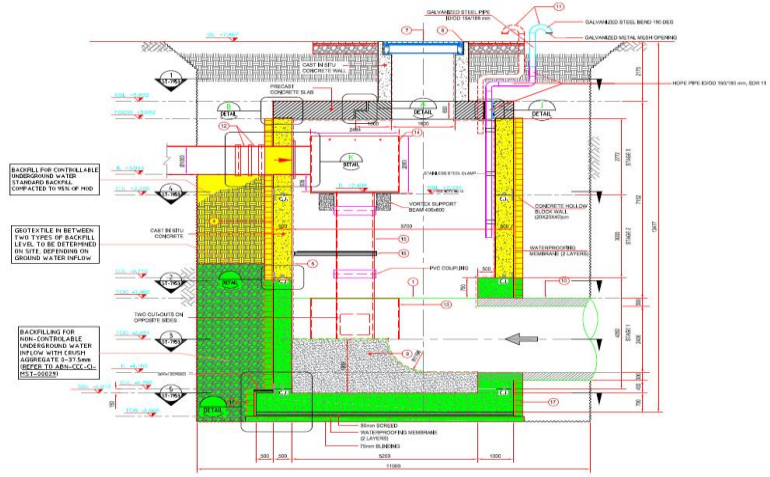
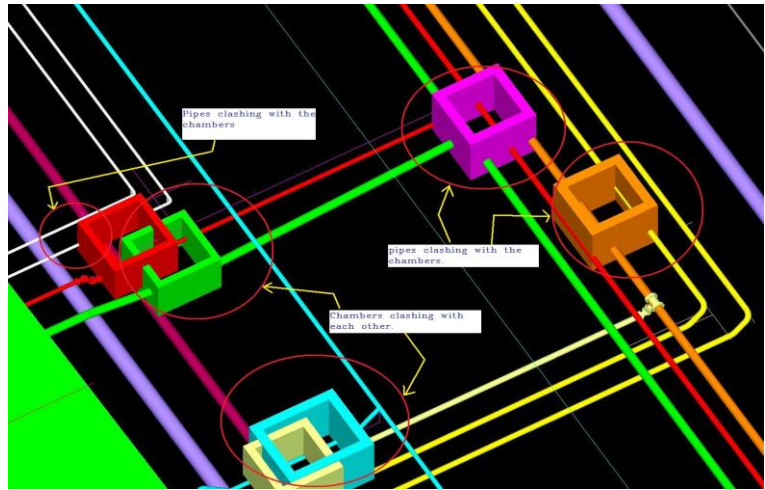
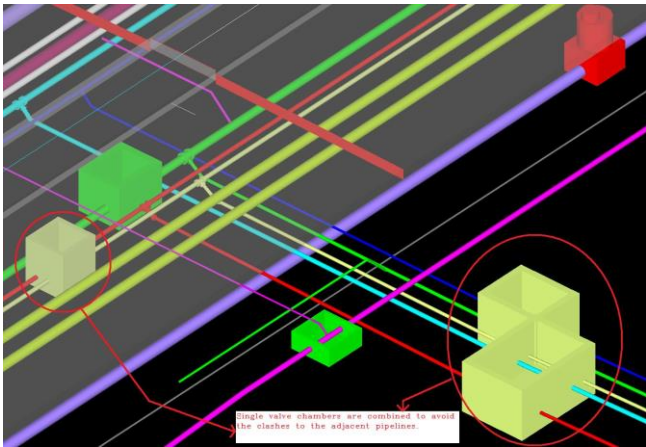
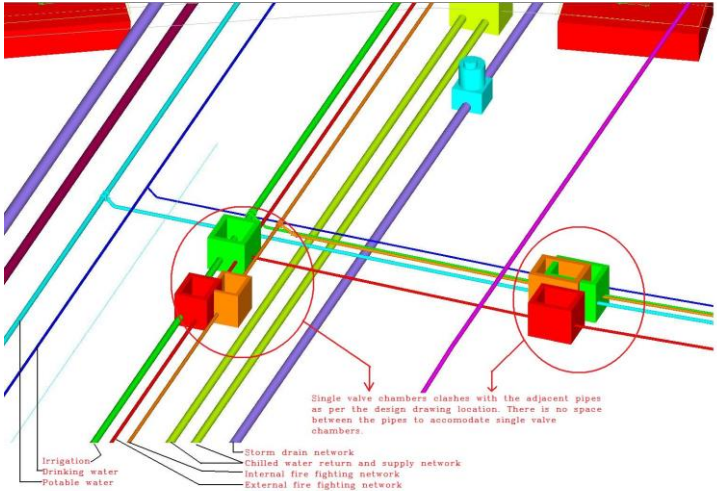

MUSCAT INTERNATIONAL AIRPORT - INFRASTRUCTURE WORKS

BIM AUTHORIZING FOR ALL DISCIPLINES

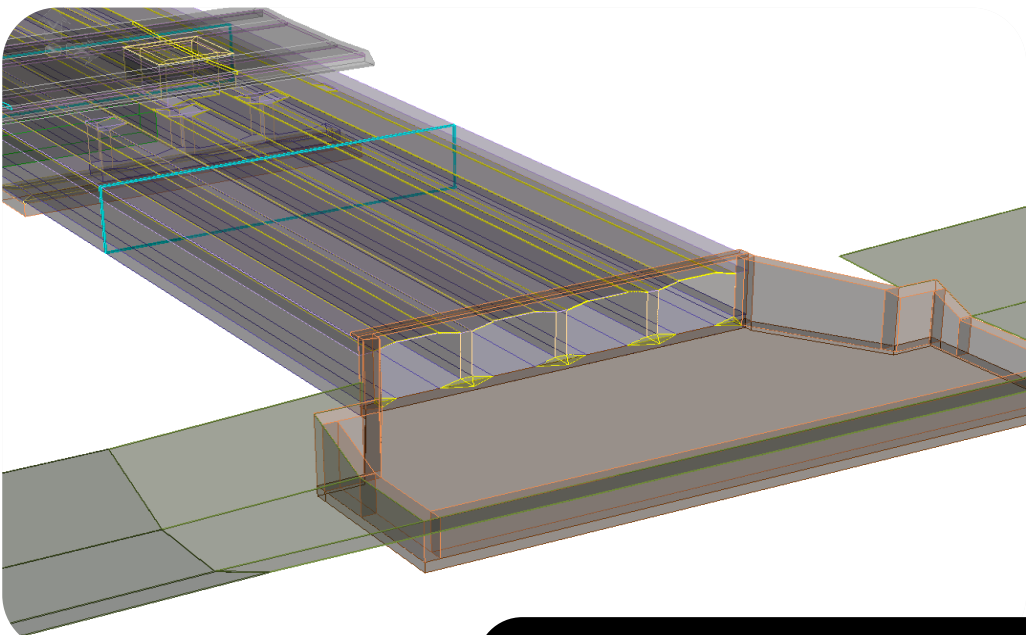

Storm Water Drainage (Box Drain)



Airfield Lighting

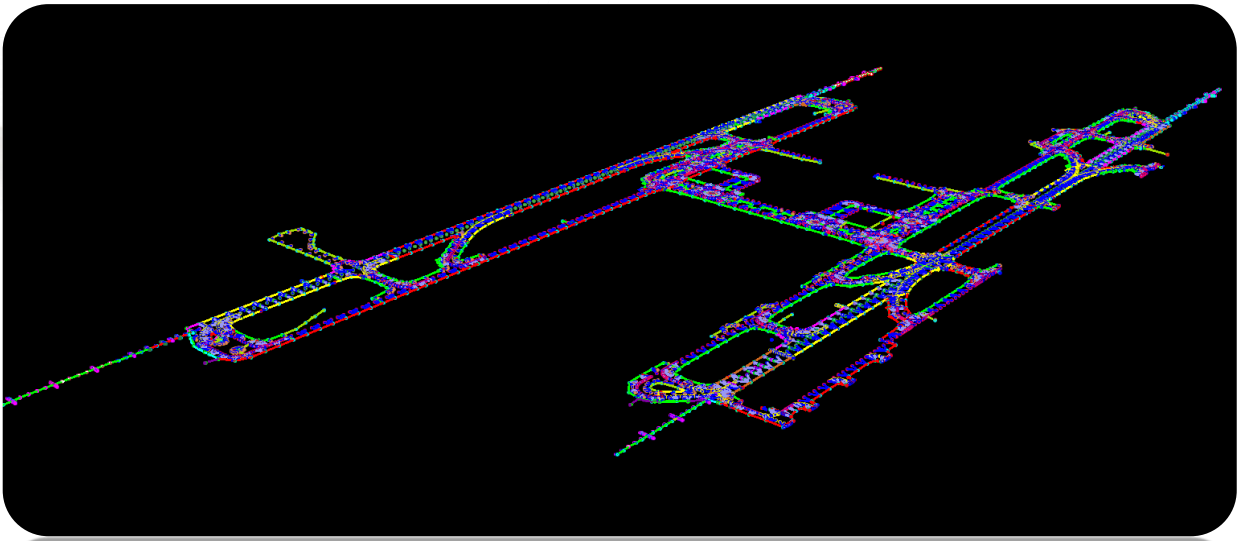

MUSCAT INTERNATIONAL AIRPORT - INFRASTRUCTURE WORKS

BIM AUTHORIZING FOR ALL DISCIPLINES

Bridge 181

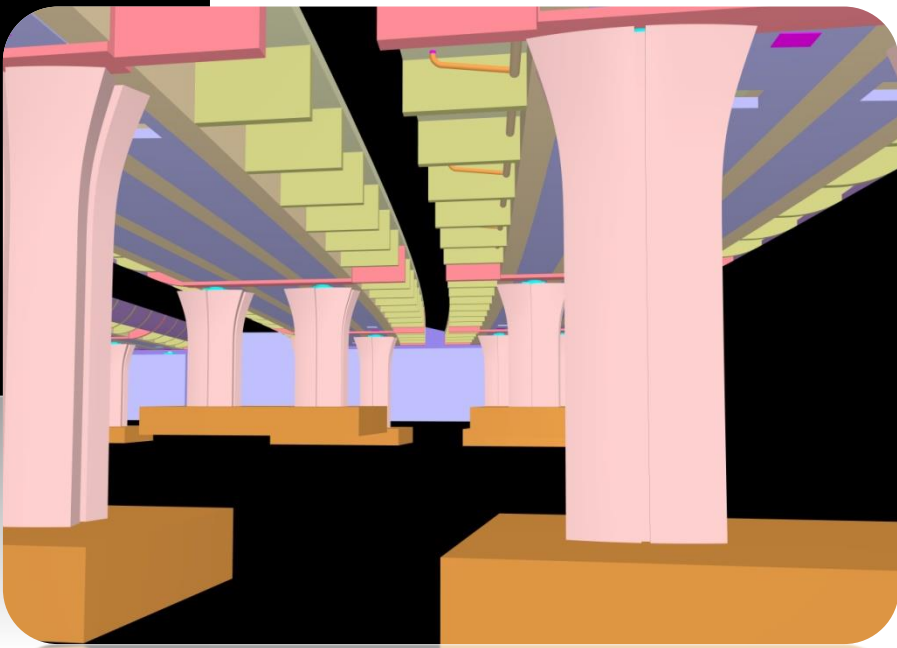
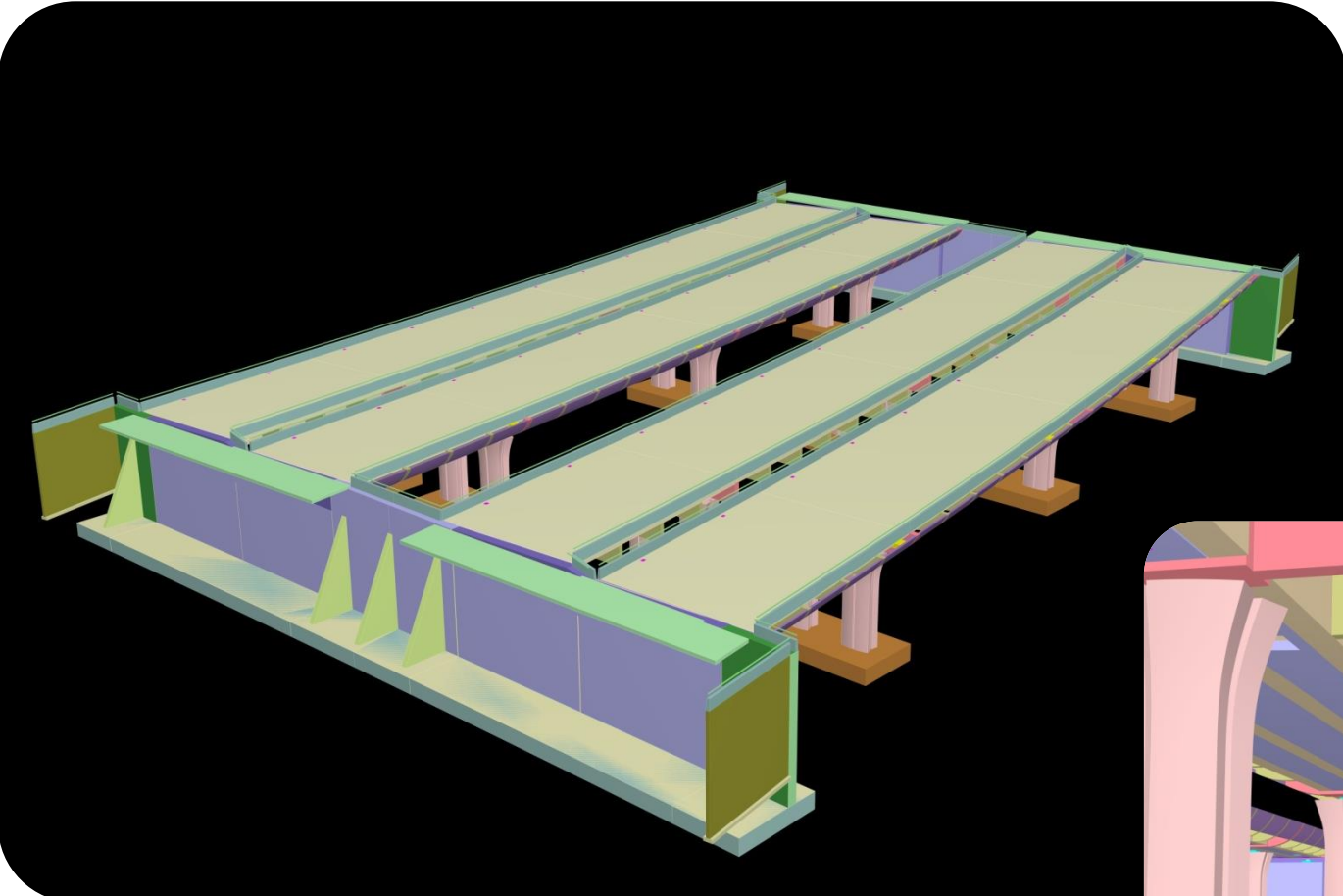

MUSCAT INTERNATIONAL AIRPORT - INFRASTRUCTURE WORKS

BIM AUTHORIZING FOR ALL DISCIPLINES



Northern Runway and
Taxiway System

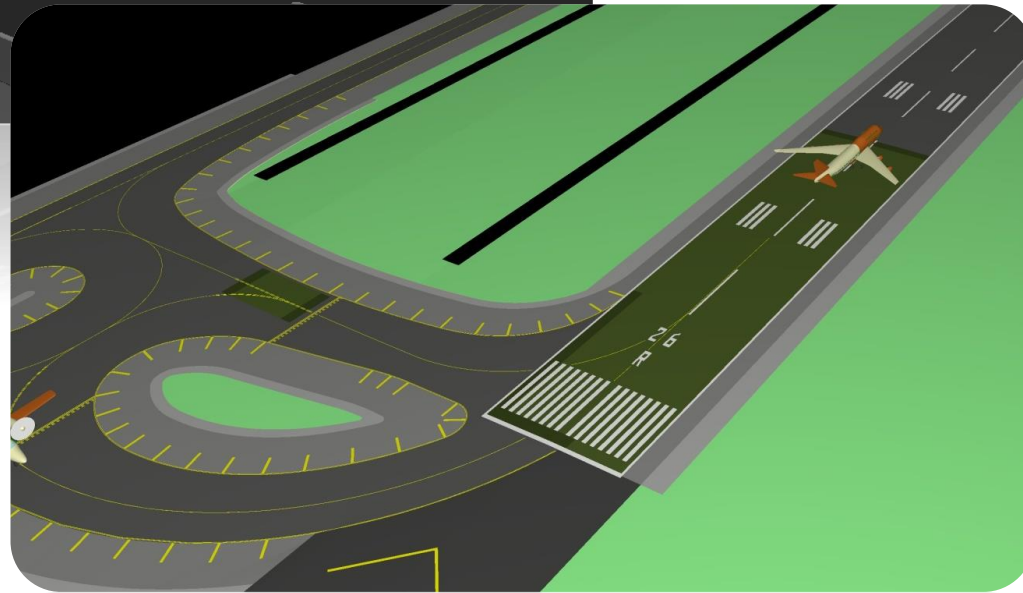

Bridge 185



Bridge 182



CLASH DETECTION

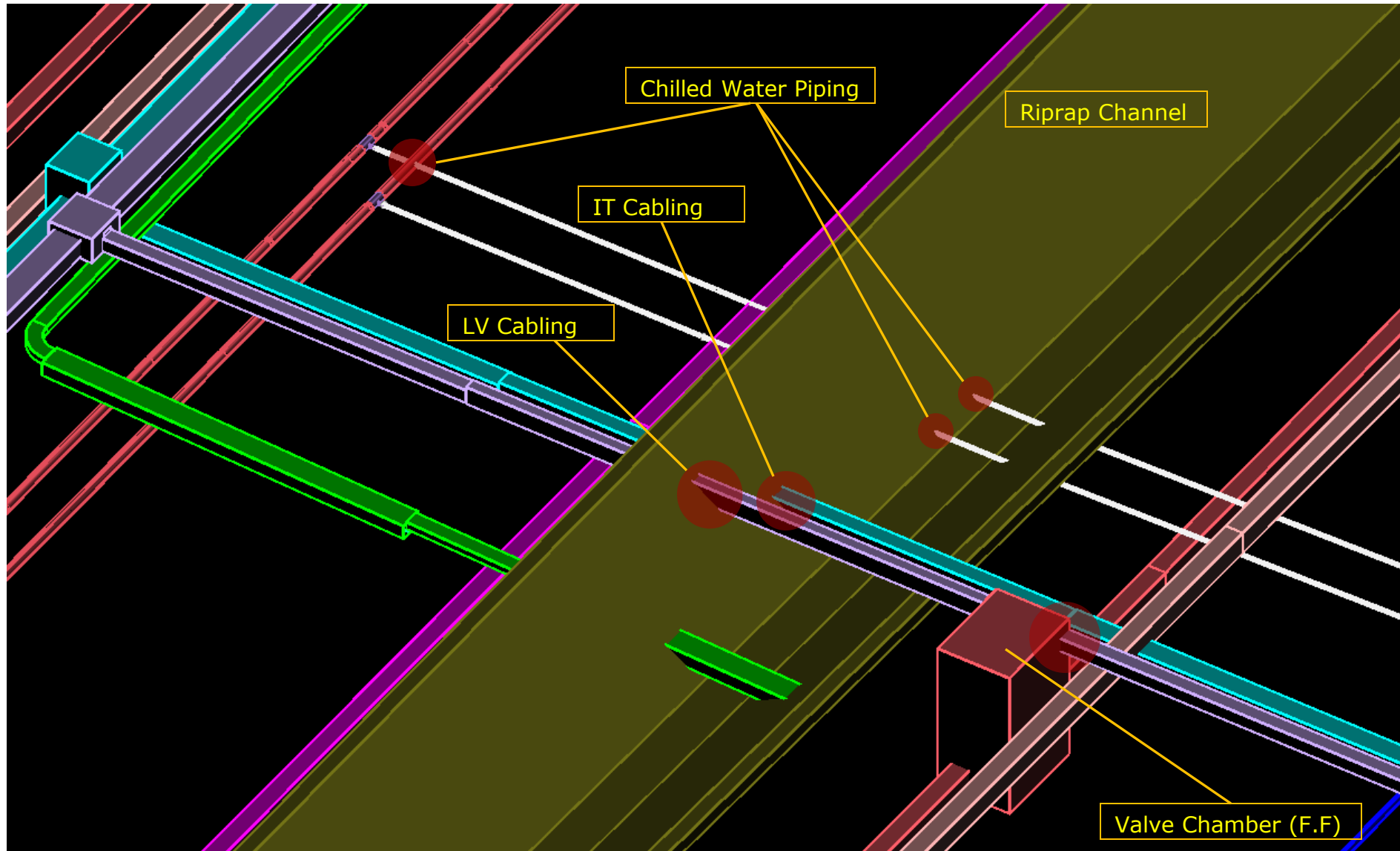

3D BIM Model (NDA Utilities)

DRAWING EXTRACTION

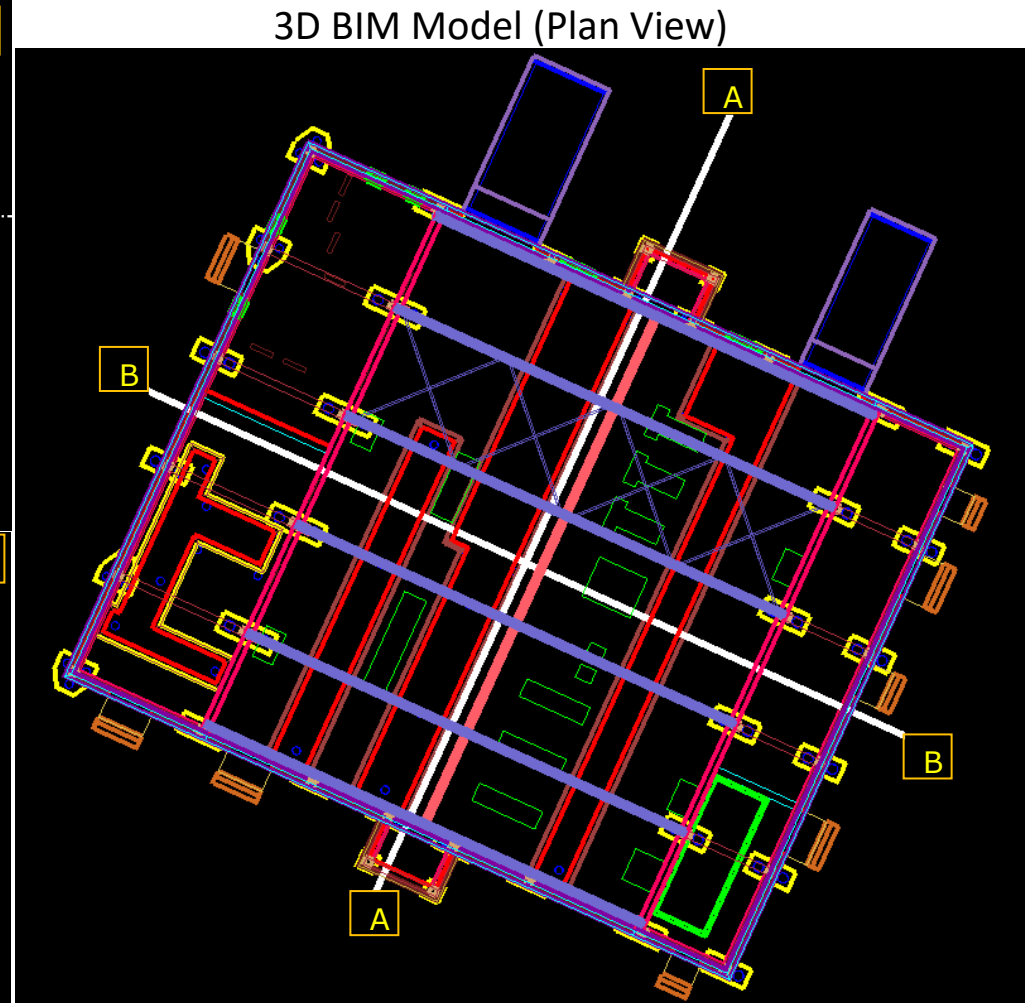
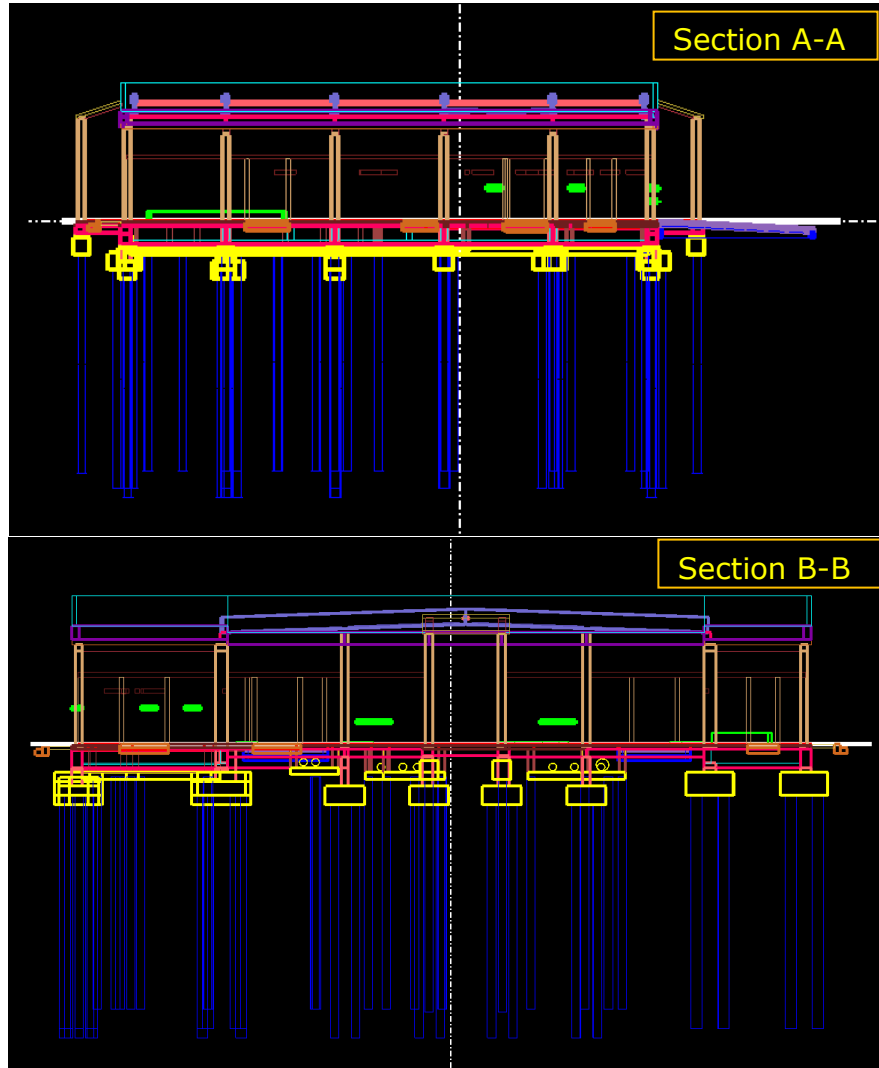

MATERIAL, OBJECT ATTRIBUTES AND SPACE TAGGING AND MANAGEMENT

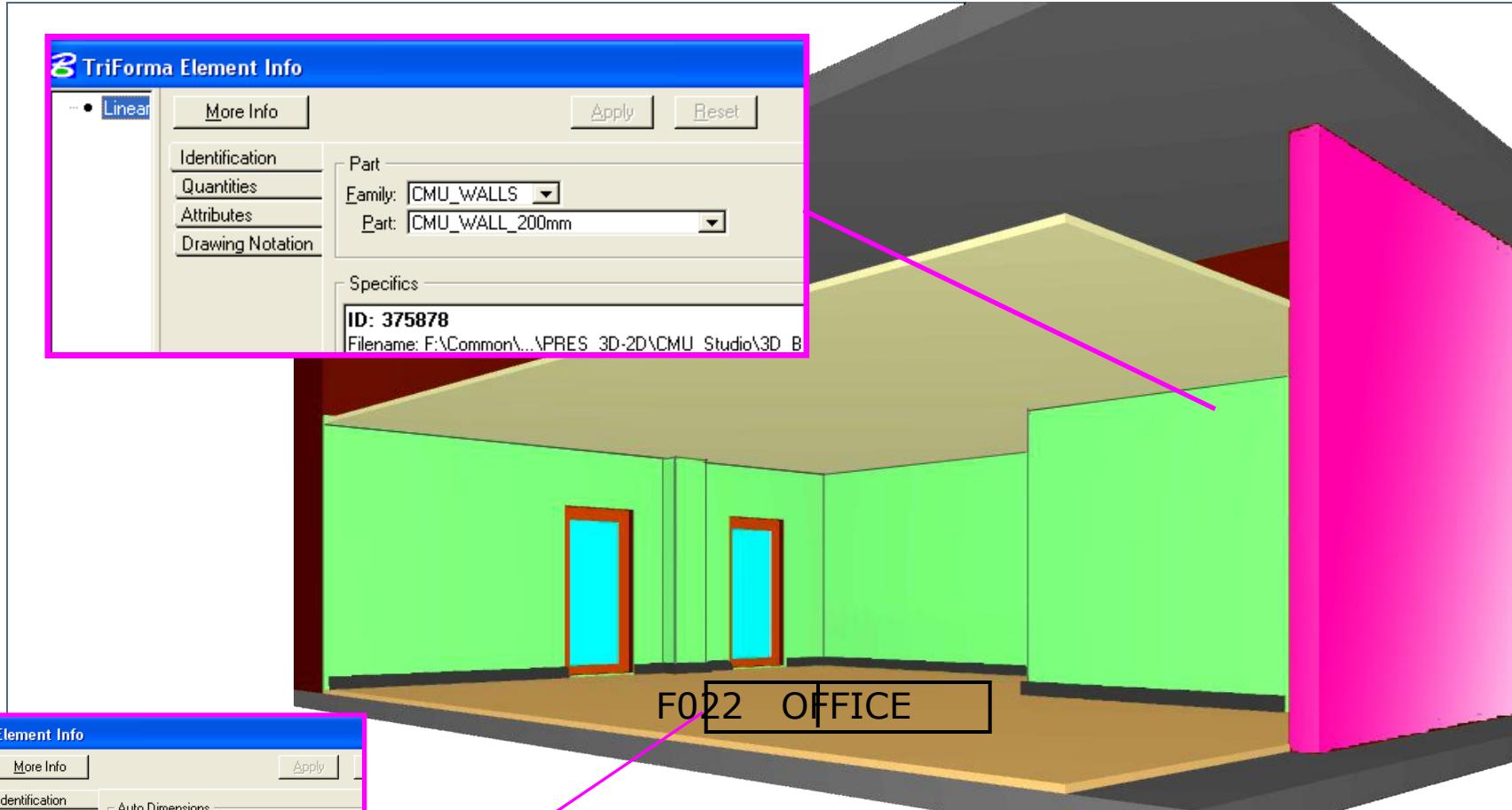

TriForma Element Info

Linear

Identification

Quantities

Attributes

Drawing Notation

Part

Family: CMU_WALLS

Part: CMU_WALL_200mm

Specifics

ID: 375878

Filename: F:\Common\...PRES_3D-2D\CMU_Studio\3D_B

riForma Element Info

Linear

Identification

Quantities

Attributes

Drawing Notation

Auto Dimensions

Type

1: None

2: None

3: None

4: None

Label: F022

SCOPE MANAGEMENT AND BOQ INTEGRATION

- Full MTO (Material Take-Off) is extracted from the BIM model detailed to the BOQ level.
- The BIM based BOQ is compared to the client BOQ.

| A | B | C | D | E |
|---|---|-------------------------------|----------|----------------|
| DEVELOPMENT OF MUSCAT INTERNATIONAL AIRPORT: MAIN CONTRACT 1 | | RUNWAYS, TAXIWAYS & APRONS | | |
| Item Ref. | Description | Unit | Quantity | BIM Quantities |
| | <u>300 GRANULAR & STABILISED SUBBASE, BASECOURSE & STABILISED SUBGRADE</u> | | | |
| | <u>302 Granular Subbase</u> | | | |
| 302-1 | Granular subbase course (class A), up to 150 mm thick | m3 | 328,390 | 330,311 |
| 302-2 | Granular subbase course (class A), 250 mm thick | m3 | 47,050 | 58,104 |
| | <u>303 Aggregate Basecourse</u> | | | |
| 303-1 | Crushed aggregate basecourse (class B), 200 mm thick | m3 | 44,660 | 43,761 |
| 303-2 | Crushed aggregate basecourse (class B), 210 mm thick | m3 | 139,340 | 140,102 |
| 303-3 | Crushed aggregate basecourse (class B), 280 mm thick | m3 | 10,800 | 10,123 |
| 303-4 | Crushed aggregate basecourse (class B), 300 mm thick | m3 | 93,670 | 114,325 |
| 303-5 | Crushed aggregate basecourse (class B), 350 mm thick | m3 | 78,070 | 76,102 |
| 303-6 | Crushed aggregate basecourse (class B), 370 mm thick | m3 | 322,000 | 320,057 |
| 303-7 | Crushed aggregate basecourse (class B), 370 mm to 400 mm thick | m3 | 160 | #N/A |
| 303-8 | Crushed aggregate basecourse (class B), exceeding 400 mm thick | m3 | 660 | #N/A |

WATER PIPES

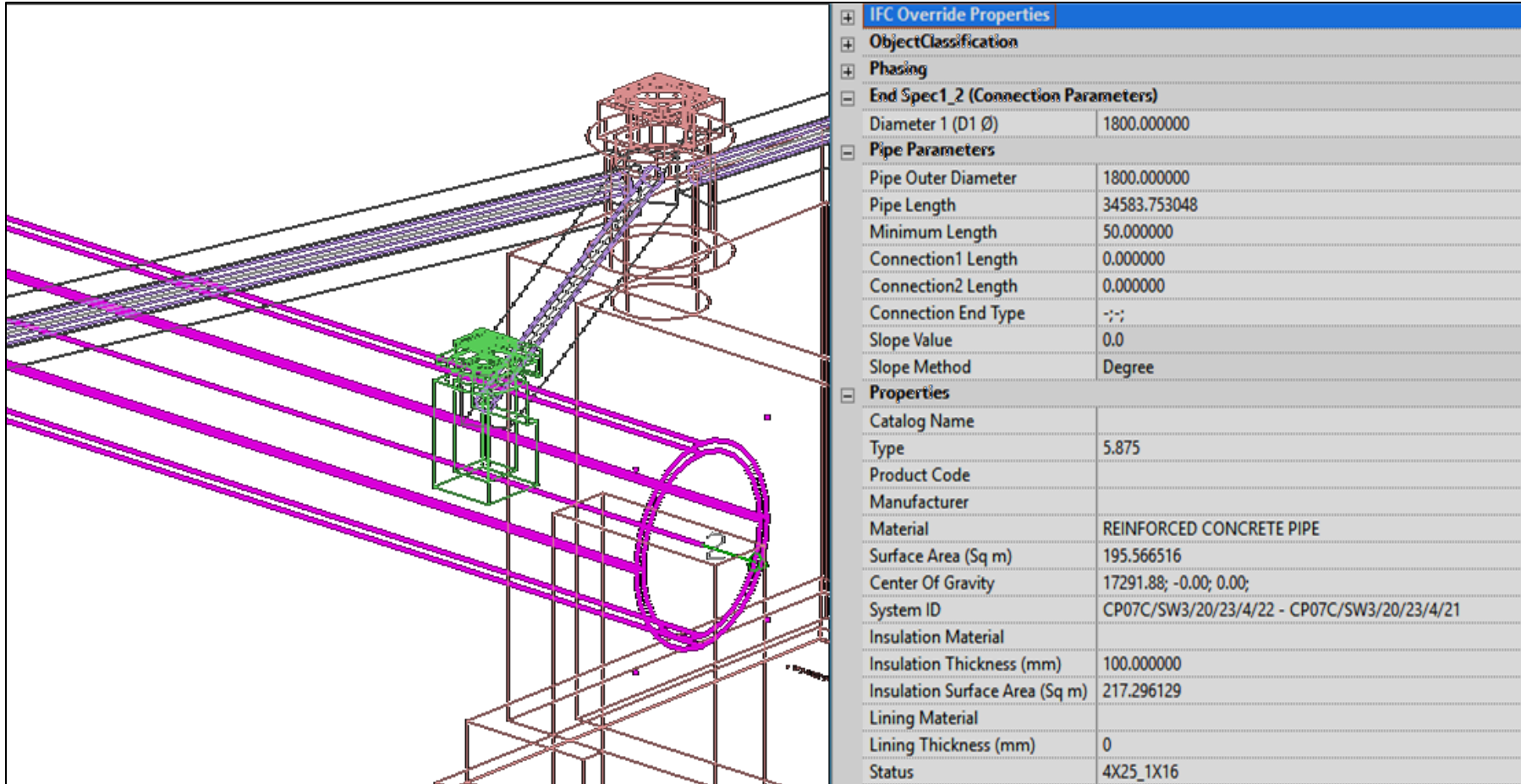

The image shows a 3D model of a water pipe network. The pipes are highlighted in purple, and the structure includes manholes and other components. To the right of the model is a properties panel for the selected pipe.

| IFC Override Properties | |
|---------------------------------------|---|
| + ObjectClassification | |
| + Phasing | |
| - End Spec1_2 (Connection Parameters) | |
| Diameter 1 (D1 Ø) | 1800.000000 |
| - Pipe Parameters | |
| Pipe Outer Diameter | 1800.000000 |
| Pipe Length | 34583.753048 |
| Minimum Length | 50.000000 |
| Connection1 Length | 0.000000 |
| Connection2 Length | 0.000000 |
| Connection End Type | -;-; |
| Slope Value | 0.0 |
| Slope Method | Degree |
| - Properties | |
| Catalog Name | |
| Type | 5.875 |
| Product Code | |
| Manufacturer | |
| Material | REINFORCED CONCRETE PIPE |
| Surface Area (Sq m) | 195.566516 |
| Center Of Gravity | 17291.88; -0.00; 0.00; |
| System ID | CP07C/SW3/20/23/4/22 - CP07C/SW3/20/23/4/21 |
| Insulation Material | |
| Insulation Thickness (mm) | 100.000000 |
| Insulation Surface Area (Sq m) | 217.296129 |
| Lining Material | |
| Lining Thickness (mm) | 0 |
| Status | 4X25_1X16 |

PIPING DATA:

- PIPE DIAMETER
- AVERAGE PIPE DEPTH STORED IN DATAGROUP TYPE PROPERTY
- PIPE MATERIAL
- PIPE ID AS PER PROJECT DRAWINGS
- PIPE THICKNESS
- LIBRARY PART

GRAVITY STORM WATER NETWORK:

- MANHOLES
- **PIPES**
- GULLIES
- CONCRETE ENCASEMENT

ASSET TAGGING AND ASSET MANAGEMENT AND DETAILED MTO STORMWATER CONCRETE DUCTS AND SEWAGE NETWORK

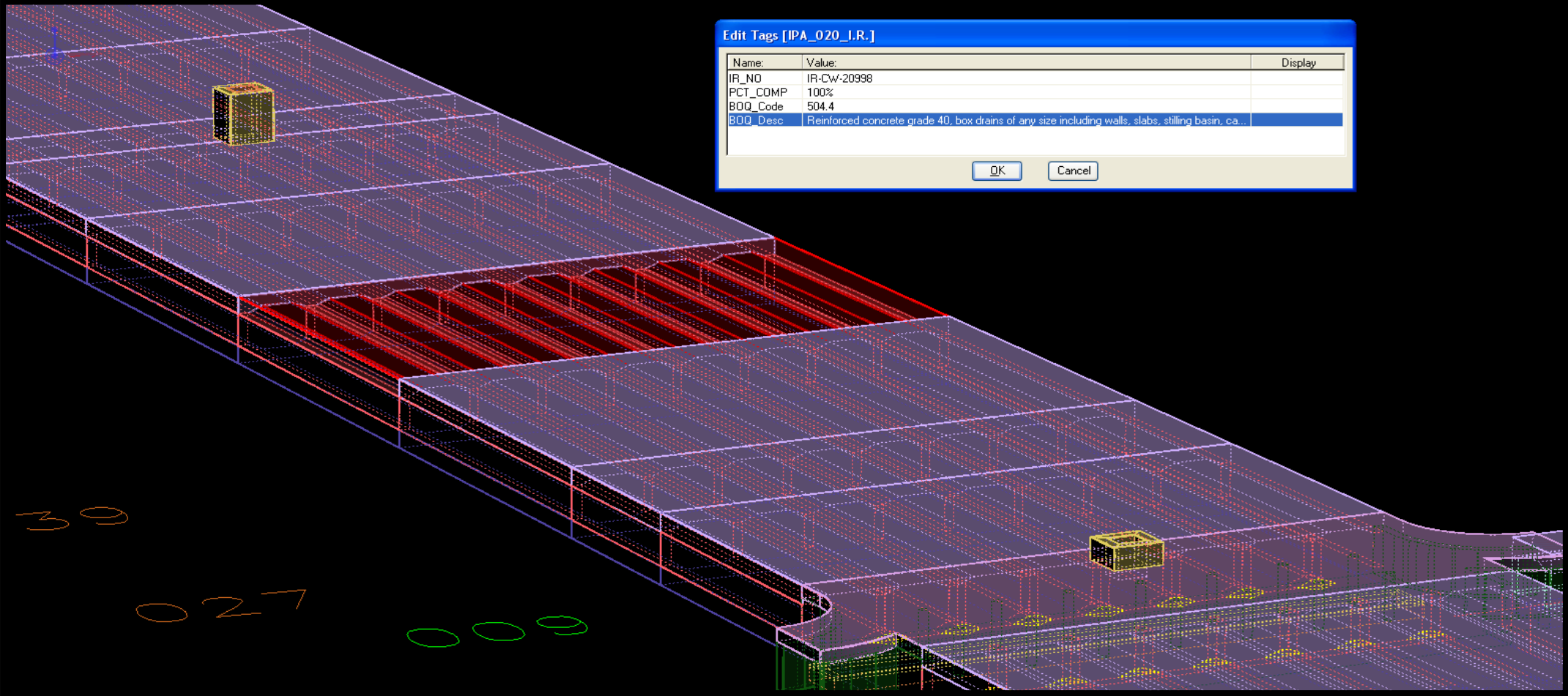

QC TRACKING + PROGRESS INTEGRATION

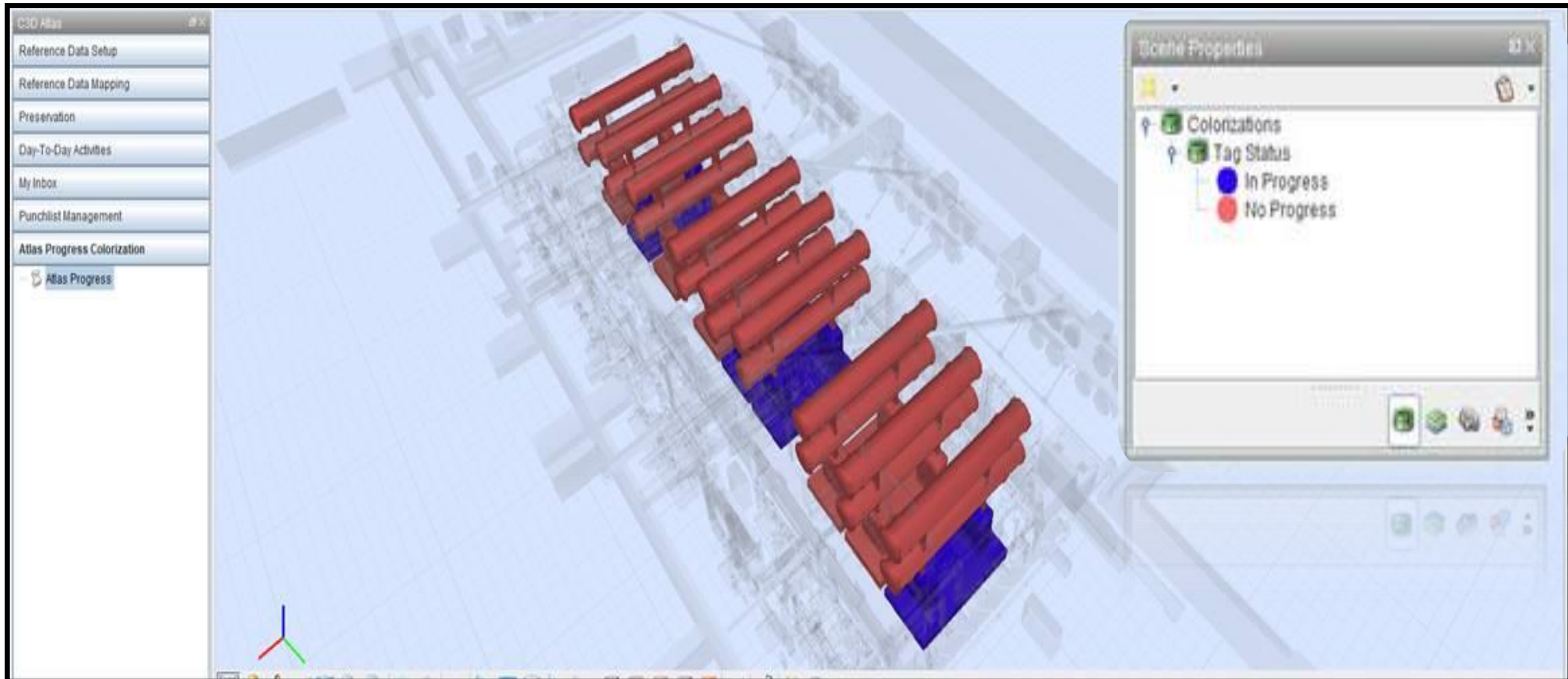

ASSET TAGGING AND ASSET MANAGEMENT AND DETAILED MTO

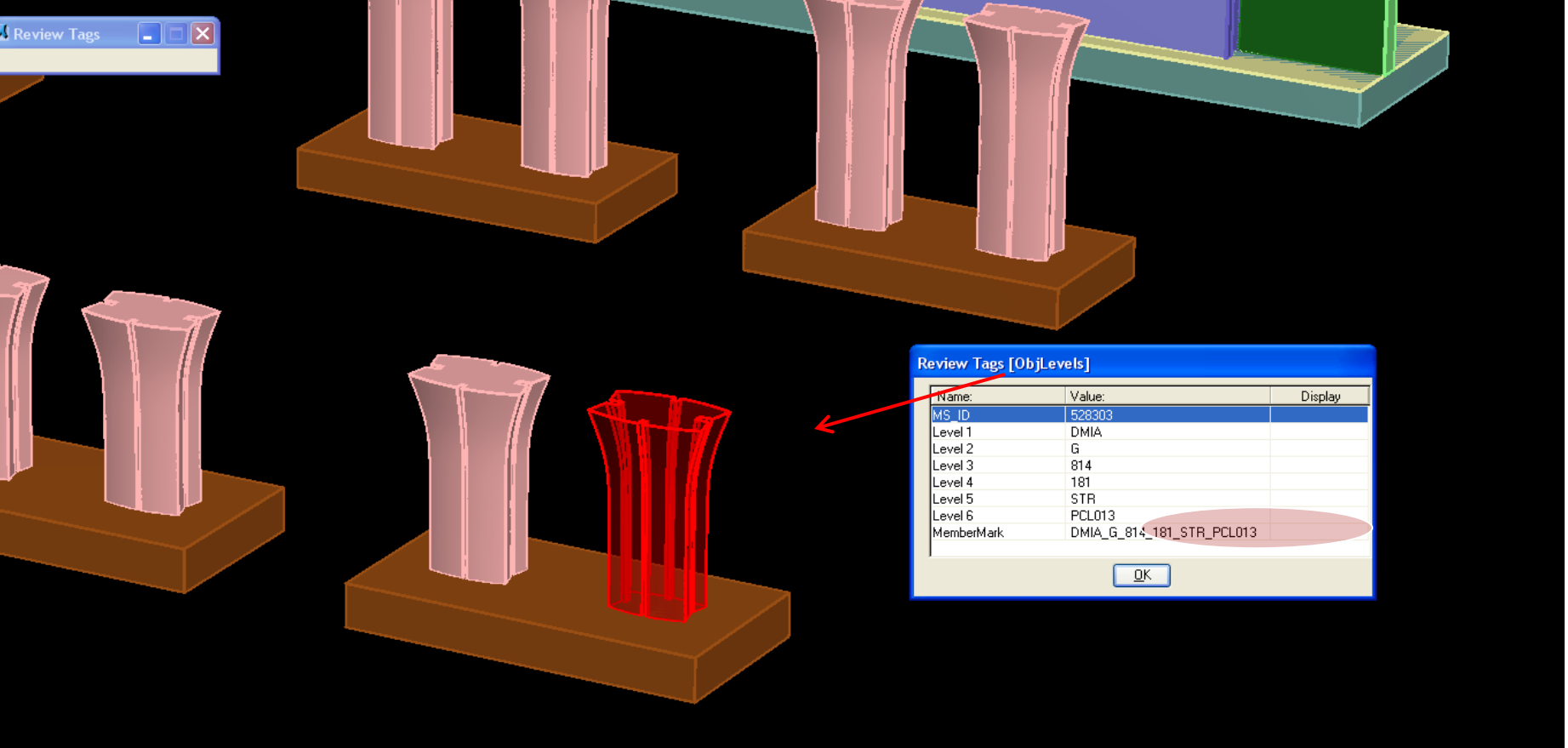

| Member Mark | Commodity Code | Pyramid Tag | Axis (from) | Axis (to) | Code | Description | QTY. | Unit |
|--------------------------------|----------------|-------------|-------------|-----------|-------|---|--------|------|
| 1534 DMIA_G_814_181_STR_PCL012 | 071.01 | RLB81EF | C-15 | C-14 | 702-2 | To sides of piers | 77.763 | m2 |
| 1535 DMIA_G_814_181_STR_PCL012 | 003.01 | RLB81EF | C-15 | C-14 | 504-9 | To piers in bridge no.181 including plinth as shown on drawing No. SE-181-814-C-21(| 36.897 | m3 |
| 1536 DMIA_G_814_181_STR_PCL013 | 071.01 | RLB81WF | C-07 | C-06 | 702-2 | To sides of piers | 72.992 | m2 |
| 1537 DMIA_G_814_181_STR_PCL013 | 003.01 | RLB81WF | C-07 | C-06 | 504-9 | To piers in bridge no.181 including plinth as shown on drawing No. SE-181-814-C-21(| 34.789 | m3 |
| 1538 DMIA_G_814_181_STR_PCL014 | 003.01 | RLB81WF | C-05 | C-04 | 504-9 | To piers in bridge no.181 including plinth as shown on drawing No. SE-181-814-C-21(| 34.758 | m3 |
| 1539 DMIA_G_814_181_STR_PCL014 | 071.01 | RLB81WF | C-05 | C-04 | 702-2 | To sides of piers | 72.921 | m2 |
| 1540 DMIA_G_814_181_STR_PCL015 | 003.01 | RLB81WF | C-04 | C-03 | 504-9 | To piers in bridge no.181 including plinth as shown on drawing No. SE-181-814-C-21(| 34.699 | m3 |
| 1541 DMIA_G_814_181_STR_PCL015 | 071.01 | RLB81WF | C-04 | C-03 | 702-2 | To sides of piers | 72.788 | m2 |

ASSET TAGGING AND ASSET MANAGEMENT AND DETAILED MTO

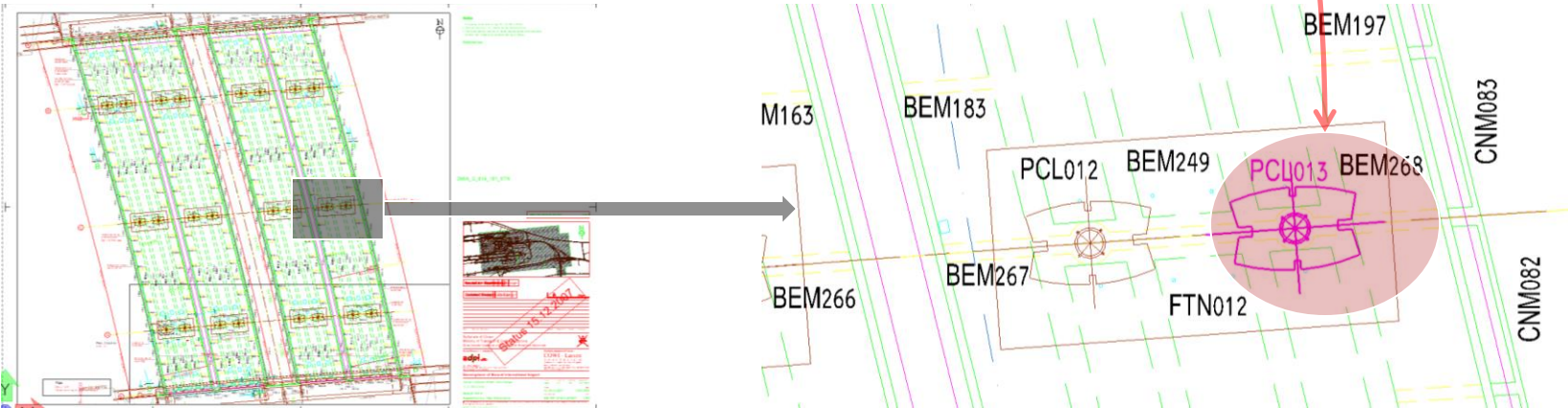
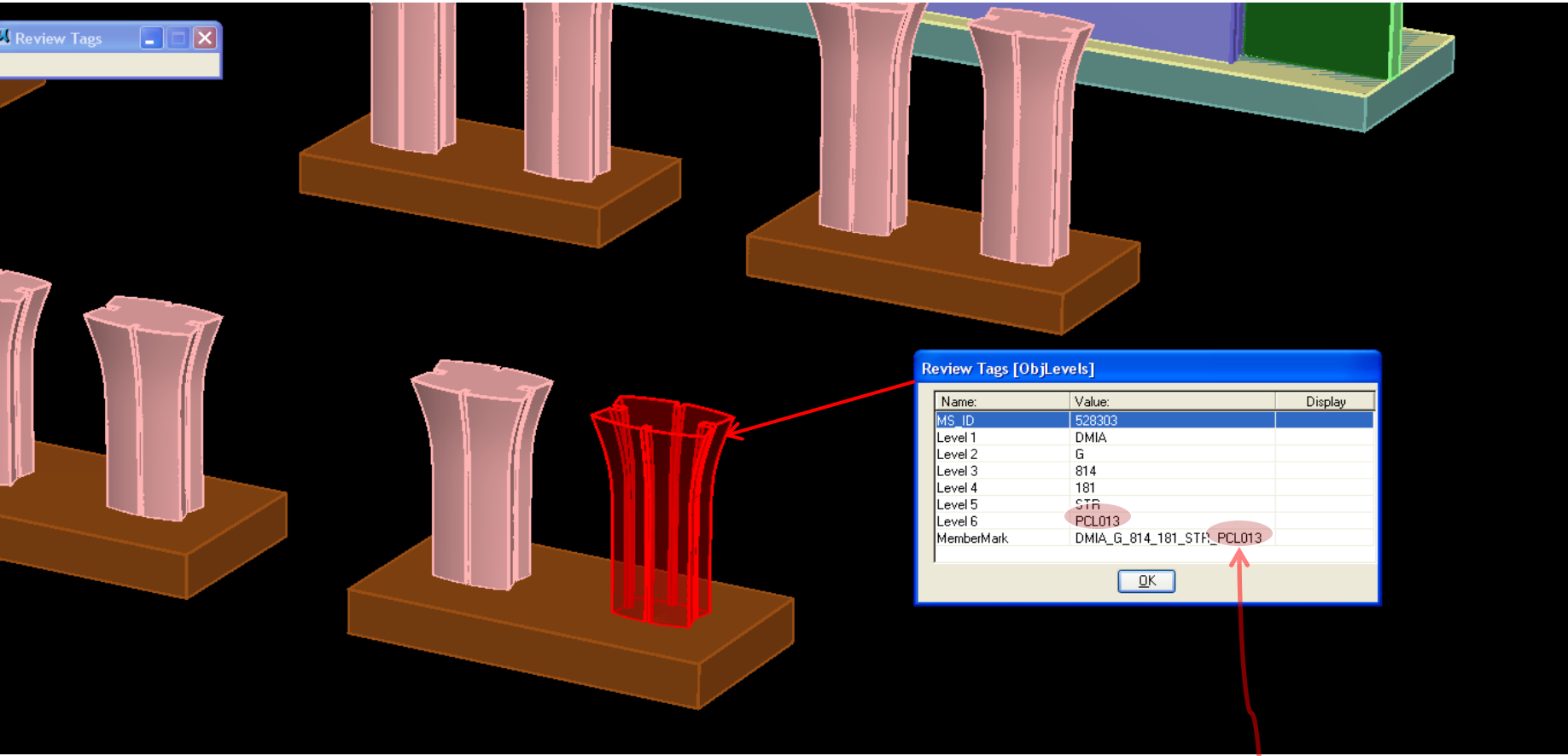

PROGRESS MONITORING AND PAYMENT CERTIFICATE

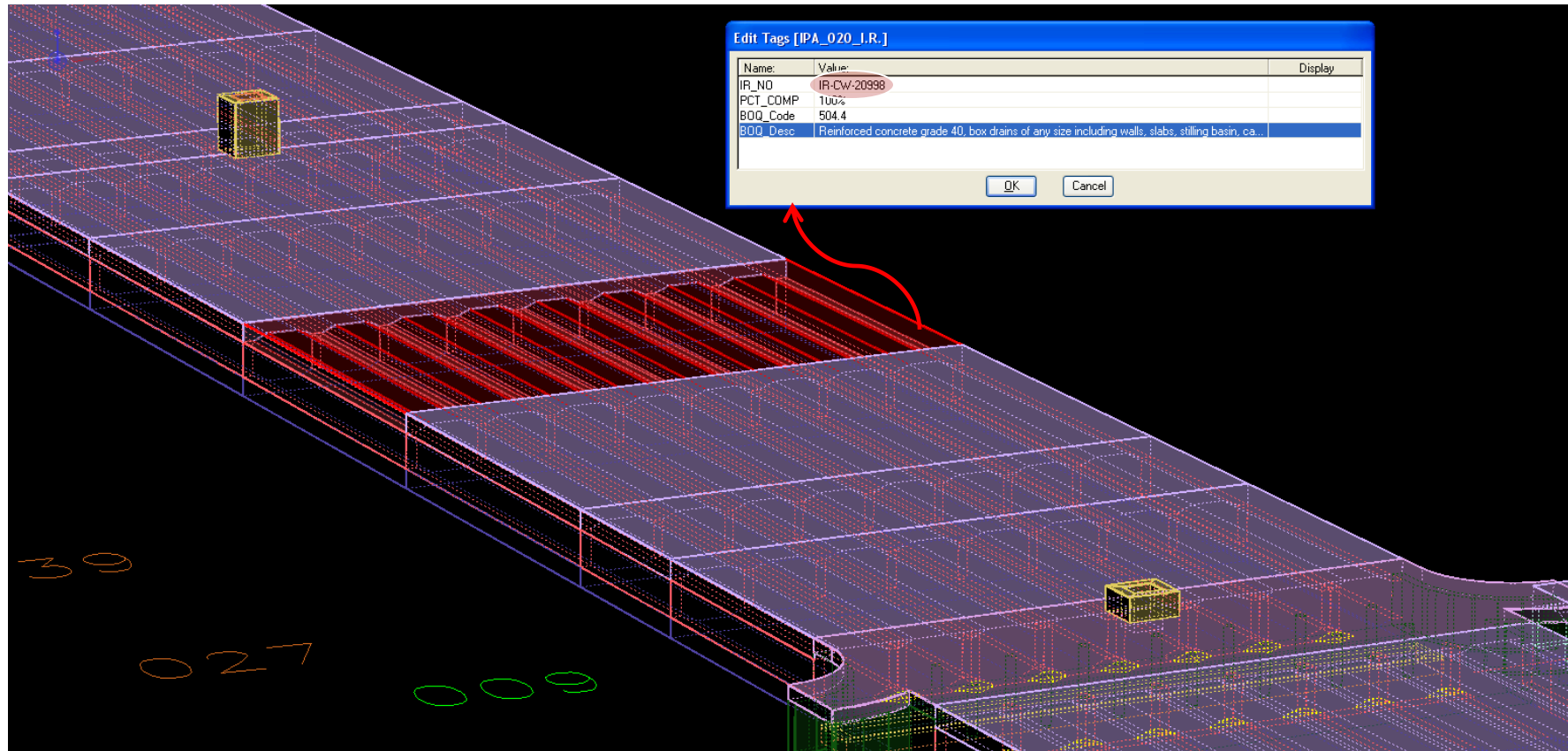

| | | | | | | |
|-----|---|----------------|---|-------------|---------------------|----------------------|
| 1 | Project Management Consultant Architects, Engineers & Planners | | COWI - Larsen | | TAV | |
| 2 | adpi | | Joint Venture | | Construction | |
| 3 | in association with Copenhagen Airports | | in association with Copenhagen Airports | | TAV | |
| 4 | DEVELOPMENT OF MUSCAT INTERNATIONAL AIRPORT (MC 1) | | | | | |
| 5 | | | | | | |
| 6 | | | | | | |
| 7 | Date: 31 January 2011 | | | | | |
| 8 | Revision: 1.0 | | | | | |
| 9 | IPA No. : DMIA_IPA_020 | | | | | |
| 10 | BILL NO. 07 - STORM WATER DRAINAGE | | | | | |
| 11 | Item Ref. 504.4 - Reinforced concrete grade 40, box drains of any size including walls, slabs, stilling basin, catch pits walls, cut off walls, headwalls, wing walls, aprons inlets, outlets and junctions etc., construction joints, expansion joints and other associated works | | | | | |
| 12 | Member Mark | IR Ref. | Unit | QTY. | % Completion | QTY Completed |
| 99 | DMIA_G_508_975_SW_D_1002887 | IR-CW-19363 | m ³ | 104.796 | 100% | 104.796 |
| 100 | DMIA_G_508_975_SW_D_1005562 | IR-CW-20996 | m ³ | 104.797 | 100% | 104.797 |
| 101 | DMIA_G_508_975_SW_D_1005690 | IR-CW-20379 | m ³ | 104.797 | 100% | 104.797 |
| 102 | DMIA_G_508_975_SW_D_1005772 | IR-CW-20352 | m ³ | 33.727 | 100% | 33.727 |
| 103 | DMIA_G_508_975_SW_D_1005971 | IR-CW-20997 | m ³ | 33.727 | 100% | 33.727 |
| 104 | DMIA_G_508_975_SW_D_1006242 | IR-CW-20998 | m ³ | 104.796 | 100% | 104.796 |
| 105 | DMIA_G_508_975_SW_D_1006406 | IR-CW-20449 | m ³ | 51.413 | 100% | 51.413 |

PROGRESS MONITORING AND PAYMENT CERTIFICATE

| | | | | | | | |
|----|---|--|----------------|----------------|---------------------|--------------------|-----------------------|
| 5 | INTERNATIONAL AIRPORT (MC 1) | | | | | | |
| 6 | | | | | | Date: | 31.January.2011 |
| 7 | | | | | | Revision: | 1.0 |
| 8 | | | | | | IPA No. : | DMIA_IPA_020 |
| 9 | BILL NO. 07 - STORM WATER DRAINAGE | | | | | | |
| 11 | Interim Payment Application No.20 | | | | | | |
| 12 | BOQ Code | Description | Unit | BOQ Qty | Previous Qty | Current Qty | Cumulative Qty |
| 13 | 504.2 | Blinding concrete grade C20, 50 mm thick below structures | m ³ | 5,800.000 | 2,700.888 | 174.134 | 2,875.022 |
| 14 | 504.4 | Reinforced concrete grade 40, box drains of any size including walls, slabs, stilling basin, catch pits walls, cut off walls, headwalls, wing walls, aprons inlets, outlets and junctions etc., construction joints, expansion joints and other associated works | m ³ | 43,740.000 | 39,267.263 | 2,532.787 | 41,800.050 |
| 15 | 504.6 | Reinforced concrete grade 40, box culverts of any size including walls, slabs, cut off walls, headwalls, wing walls, aprons, catch basins, inlets and outlets etc, construction joints, expansion joints and other associated works | m ³ | 48,300.000 | 5,823.589 | 315.716 | 6,139.305 |
| 16 | 504.18 | Concrete for Structures - Reinforced concrete grade 40, 400 mm diameter circular columns, average height 1500 mm for junctions in box drains including formwork and other associated works as per specification and | m ³ | 100.000 | 9.444 | 50.214 | 59.658 |
| 17 | 504.19 | Reinforced concrete grade 40, walls of emptying station including formwork and the like as per specification and drawings | m ³ | 110.000 | 5.384 | 0.000 | 5.384 |
| 18 | 504.20 | Reinforced concrete grade 40, cover slab of emptying station including formwork and the like as per specification and drawings | m ³ | 100.000 | 76.555 | 0.000 | 76.555 |
| 19 | 803.2 | Supply and install storm water pipes including excavation, levelling bottoms, compacting, backfilling and all associated works as per specification and drawings, Storm sewer uPVC pipe (250 mm diameter) | m | 12,410.000 | 867.230 | 128.449 | 995.679 |
| 20 | 803.11 | Supply and install storm water pipes including excavation, levelling bottoms, compacting, backfilling and all associated works as per specification and drawings, Storm sewer GRP pipe (1200 mm diameter) | m | 770.000 | 129.560 | 0.000 | 129.560 |
| 21 | 803.12 | Supply and install storm water pipes including excavation, levelling bottoms, compacting, backfilling and all associated works as per specification and drawings, Storm sewer GRP pipe (1400 mm diameter) | m | 1,100.000 | 119.393 | 5.284 | 124.677 |
| | | Pipe drain catch basin including grating and frame, stainless steel ladder, | | | | | |

CHANGE MANAGEMENT AND VARIATION SUPPORT

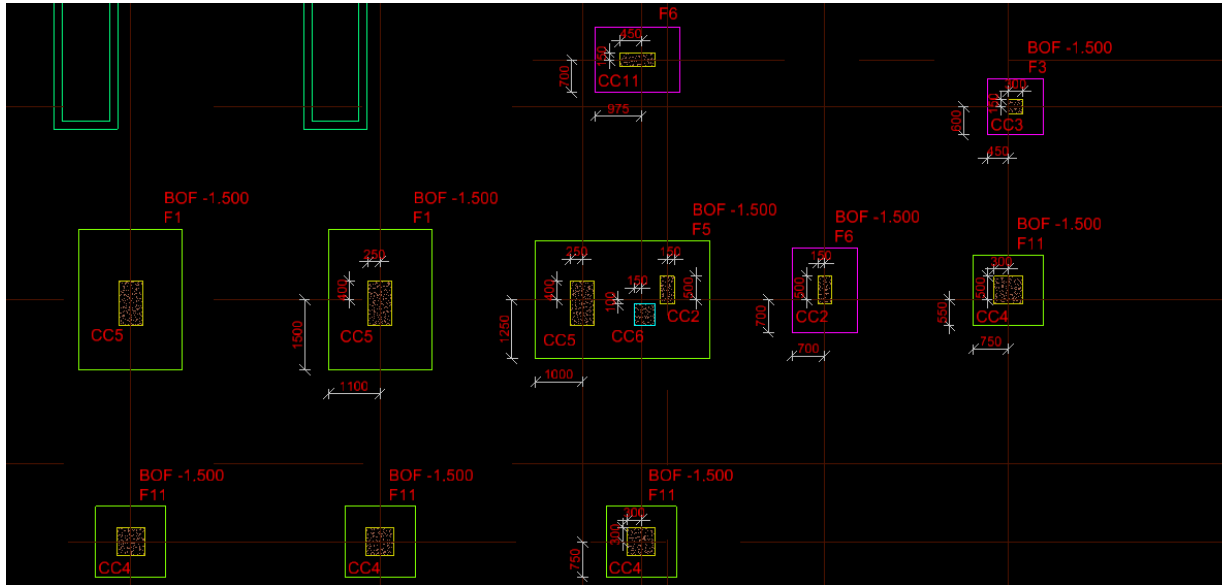

Initial DWG
(CO1)

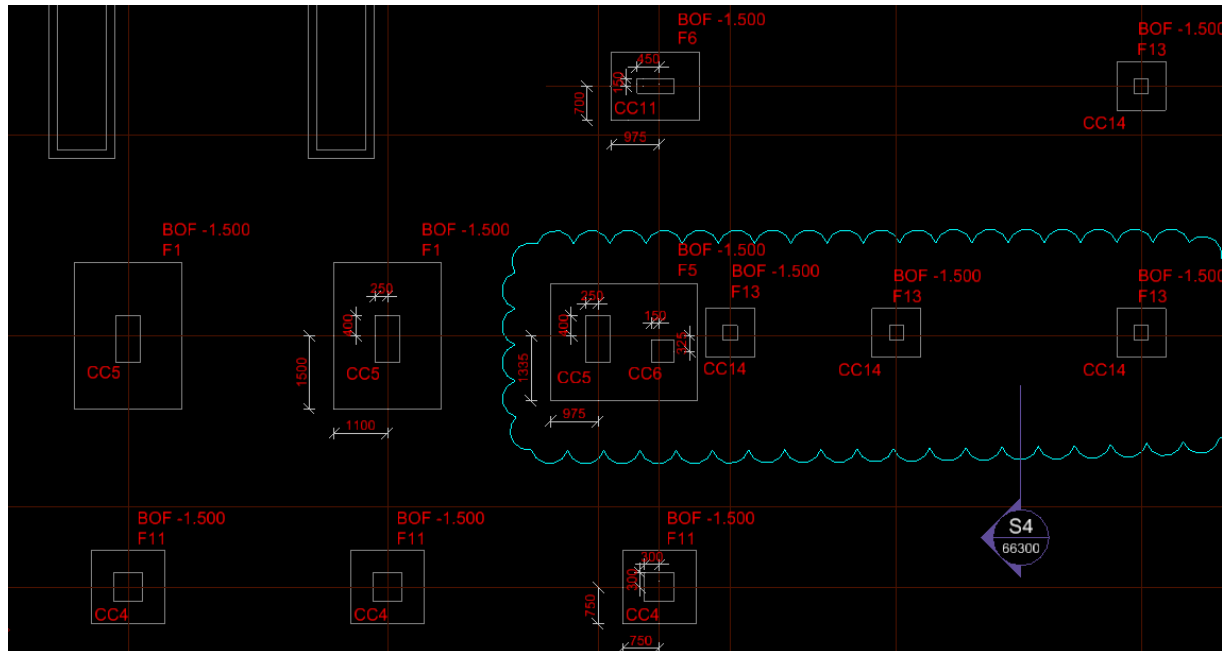

S.I.076
(CO2)

CHANGE MANAGEMENT AND VARIATION SUPPORT

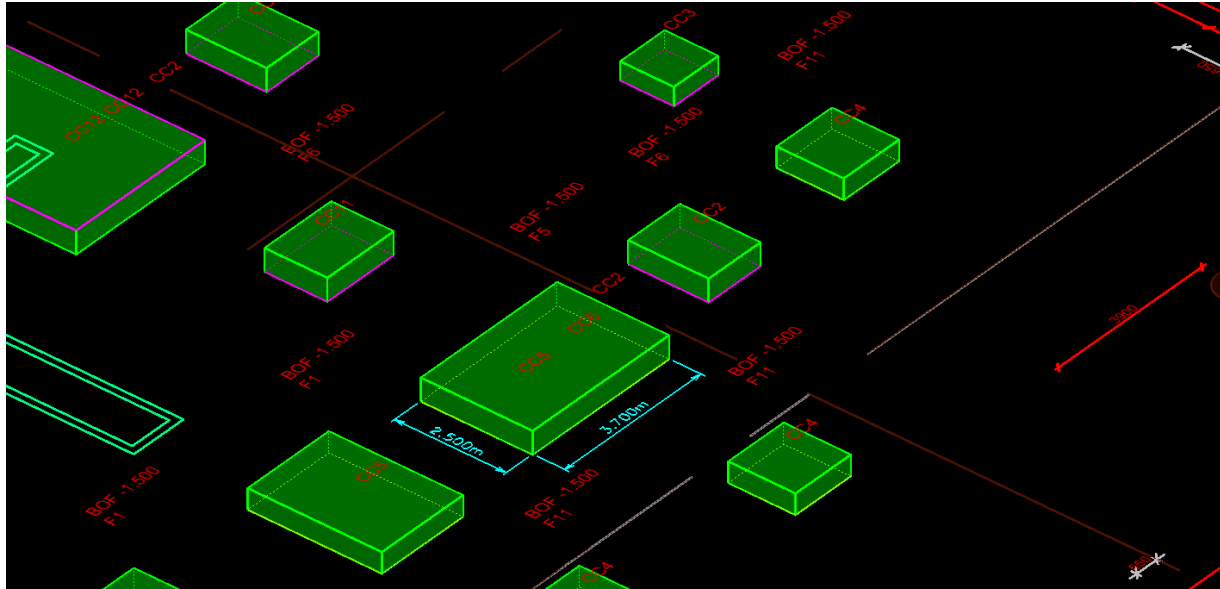

Initial 3D BIM model
(CO1)

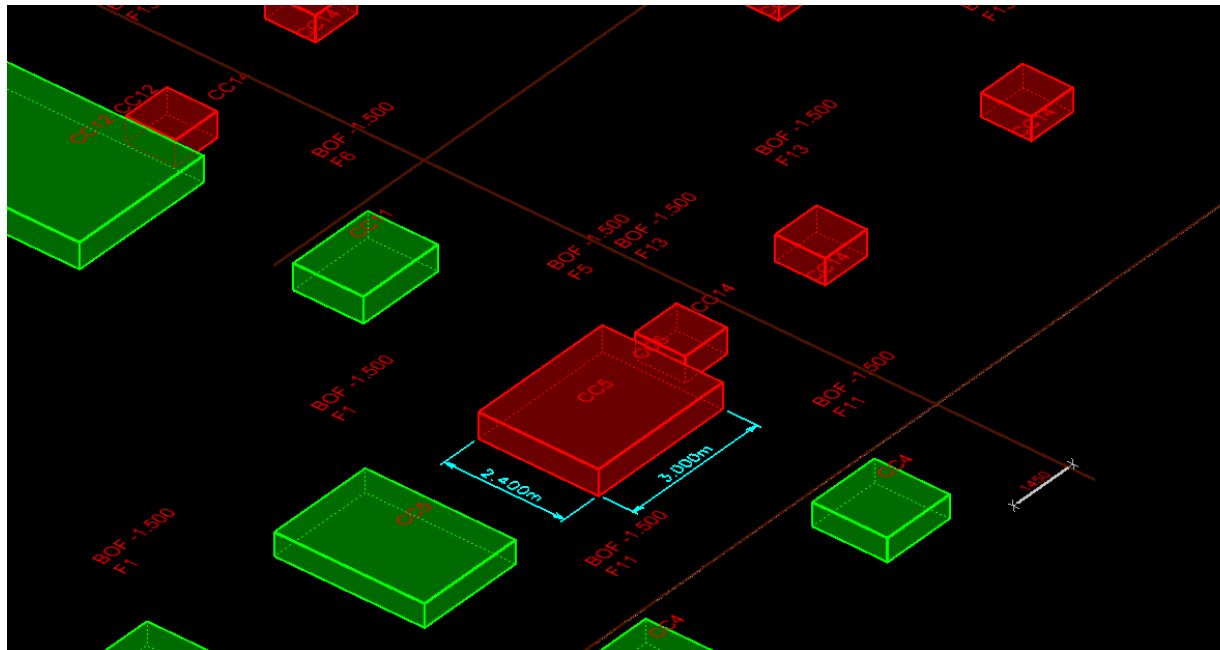

S.I.076 3D BIM model
(CO2)

VARIATION MANAGEMENT AND CLAIMS SUBSTANTIATION

USE BIM/3D MATERIAL TAKE-OFF PROCESSES TO CREATE ACCURATE AND RELIABLE PROJECT SCOPE AGGREGATED AND STRUCTURED PER THE BOQ, WBS AND PROJECT SCHEDULE

CREATE VISUAL AND INTERACTIVE 4D (TIME SIMULATION STUDIES) TO SUPPORT TIME CLAIMS SUBSTANTIATION VISUAL STUDIES

DEVELOP 3D/BIM BASED VISUAL DASHBOARDS AS AN INFORMATION SOURCE TO SUPPORT DIFFERENT LEVEL OF REPORTING AND DATA AGGREGATION FOR THE PROJECT SCOPE INCLUDING MATERIAL, SPECIFICATIONS, DISCIPLINE AND WBS OR ANY COMBINATION THAT WILL DELIVER VALUE AS A SCIENTIFIC AND OBJECTIVE CHANGE MANAGEMENT PROCESS

CHANGE MANAGEMENT AND EVALUATION (BEFORE AND AFTER STUDIES)

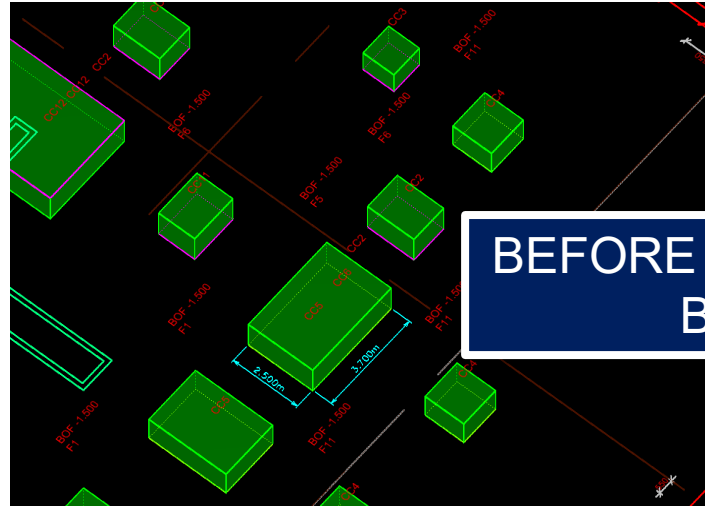

BEFORE VARIATION (BIM AND BOQ REPORT)

| DUBAI MALL PROJECT | | | | QUANTITY | UNIT |
|--|--------|----------|---|--------------------------------|------|
| DETAILED MATERIAL TAKE OFF - ZONE (3) | | | | DEVELOPED BY THE TRIFORMA TEAM | |
| FILE | DIV | CODE | DESCRIPTION | | |
| ZONE 3 - SUBZONE A - FOUNDATION LEVEL | | | | | |
| OFN-003-0A | DIV-02 | 02-02-0A | Piling, 900 mm Nominal diameter; reduced in length up to 3m | 34 | pc |
| OFN-003-0A | DIV-02 | 02-02-0K | Poured reinforced concrete, Pile caps | 106,666 | m3 |
| OFN-003-0A | DIV-02 | 02-03-0A | Poured reinforced concrete, Tie beams | 66,006 | m3 |
| OFN-003-0A | DIV-02 | 02-03-0J | Poured reinforced concrete, Perimeter retaining walls; 400 mm thick | 106,644 | m3 |
| OFN-003-0A | DIV-02 | 02-03-0R | Shuttering, Sides of pile caps | 154,148 | m2 |
| OFN-003-0A | DIV-02 | 02-04-0A | Shuttering, Sides of the beams | 87,54 | m2 |
| OFN-003-0A | DIV-02 | 02-04-0K | Shuttering, Sides of perimeter retaining walls | 533,218 | m2 |
| OFN-003-0A | DIV-02 | 02-05-0M | Protected bituminous sheet membrane waterproofing as Specification Section 07100, 50 mm thick; vertically to pile heads | 154,148 | m2 |
| OFN-003-0A | DIV-02 | 02-05-0N | Protected bituminous sheet membrane waterproofing as Specification Section 07100, 50 mm thick; horizontally to pile heads | 143,904 | m2 |
| OFN-003-0A | DIV-03 | 03-02-0B | Poured reinforced concrete, Walls, 300 mm thick | 6,63 | m3 |
| | | | | 11,856 | m3 |
| | | | | 103,48 | m2 |
| | | | | 2 | pc |
| | | | | 4,704 | m3 |
| | | | | 13,44 | m2 |
| | | | | 71,015 | m2 |
| | | | | 13,44 | m2 |
| | | | | 3,92 | m2 |
| | | | | 146,265 | m3 |
| | | | | 103,341 | m3 |
| | | | | 516,706 | m2 |
| | | | | 2 | pc |
| OFN-003-0C | DIV-02 | 02-03-0A | Poured reinforced concrete, Tie beams | 25,66 | m3 |
| OFN-003-0C | DIV-02 | 02-04-0A | Shuttering, Sides of tie beams | 85,2 | m2 |
| OFN-003-0D | DIV-02 | 02-02-0A | Piling, 900 mm Nominal diameter; reduced in length up to 3m | 8 | pc |
| OFN-003-0D | DIV-02 | 02-02-0K | Poured reinforced concrete, Pile caps | 294,032 | m3 |
| OFN-003-0D | DIV-02 | 02-03-0A | Poured reinforced concrete, Tie beams | 12,78 | m3 |
| OFN-003-0D | DIV-02 | 02-03-0R | Shuttering, Sides of pile caps | 377,88 | m2 |
| OFN-003-0D | DIV-02 | 02-04-0A | Shuttering, Sides of tie beams | 42,6 | m2 |
| OFN-003-0D | DIV-02 | 02-04-0C | Shuttering, Sides of non suspended slabs | 88,016 | m2 |
| OFN-003-0D | DIV-02 | 02-05-0M | Protected bituminous sheet membrane waterproofing as Specification Section 07100, 50 mm thick; vertically to pile heads | 377,88 | m2 |
| OFN-003-0D | DIV-02 | 02-05-0N | Protected bituminous sheet membrane waterproofing as Specification Section 07100, 50 mm thick; horizontally to pile heads | 125,12 | m2 |
| OFN-003-0D | DIV-02 | 02-50-0B | Poured reinforced concrete, Non suspended slab, 250 mm thick | 96,705 | m3 |

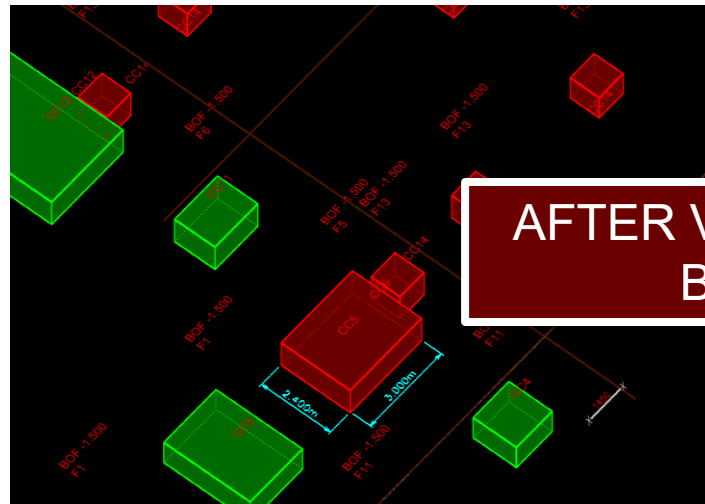

AFTER VARIATION (BIM AND BOQ REPORT)

| DUBAI MALL PROJECT | | | | QUANTITY | UNIT |
|--|--------|----------|---|--------------------------------|------|
| DETAILED MATERIAL TAKE OFF - ZONE (3) | | | | DEVELOPED BY THE TRIFORMA TEAM | |
| MEMBER MARK | DIV | CODE | DESCRIPTION | | |
| ZONE 3 - SUBZONE A - FOUNDATION LEVEL | | | | | |
| P-37A-0FN-003-0A | DIV-02 | 02-02-0A | Piling, 900 mm Nominal diameter; reduced in length up to 3m | 1 | pc |
| P-37A-0FN-003-0A | DIV-02 | 02-02-0K | Poured reinforced concrete, Pile caps | 2,352 | m3 |
| P-37A-0FN-003-0A | DIV-02 | 02-05-0M | Protected bituminous sheet membrane waterproofing as Specification Section 07100, 50 mm thick; vertically to pile heads | 6,72 | m2 |
| P-37A-0FN-003-0A | DIV-02 | 02-05-0N | Protected bituminous sheet membrane waterproofing as Specification Section 07100, 50 mm thick; horizontally to pile heads | 1,96 | m2 |
| G-37A-37B-0FN-003-0A | DIV-02 | 02-03-0A | Poured reinforced concrete, Tie beams | 3,195 | m3 |
| P-38A-0FN-003-0A | DIV-02 | 02-02-0A | Piling, 900 mm Nominal diameter; reduced in length up to 3m | 1 | pc |
| | | | | 2,352 | m3 |
| | | | | 6,72 | m2 |
| | | | | 1,96 | m2 |
| | | | | 3,195 | m3 |
| | | | | 2,352 | m3 |
| | | | | 6,72 | m2 |
| | | | | 1,96 | m2 |
| | | | | 3,195 | m3 |
| | | | | 1 | pc |
| | | | | 2,352 | m3 |
| P-40A-0FN-003-0A | DIV-02 | 02-05-0M | Protected bituminous sheet membrane waterproofing as Specification Section 07100, 50 mm thick; vertically to pile heads | 6,72 | m2 |
| G-40A-04B-0FN-003-0A | DIV-02 | 02-03-0A | Poured reinforced concrete, Tie beams | 3,195 | m3 |
| P-41A-0FN-003-0A | DIV-02 | 02-02-0A | Piling, 900 mm Nominal diameter; reduced in length up to 3m | 2 | pc |
| P-41A-0FN-003-0A | DIV-02 | 02-02-0K | Poured reinforced concrete, Pile caps | 10,841 | m3 |
| P-41A-0FN-003-0A | DIV-02 | 02-05-0M | Protected bituminous sheet membrane waterproofing as Specification Section 07100, 50 mm thick; vertically to pile heads | 19,08 | m2 |
| P-41A-0FN-003-0A | DIV-02 | 02-05-0N | Protected bituminous sheet membrane waterproofing as Specification Section 07100, 50 mm thick; horizontally to pile heads | 6,023 | m2 |
| G-41A-41B-0FN-003-0A | DIV-02 | 02-03-0A | Poured reinforced concrete, Tie beams | 3,139 | m3 |
| P-42A-0FN-003-0A | DIV-02 | 02-02-0A | Piling, 900 mm Nominal diameter; reduced in length up to 3m | 1 | pc |
| P-42A-0FN-003-0A | DIV-02 | 02-02-0K | Poured reinforced concrete, Pile caps | 2,352 | m3 |
| P-42A-0FN-003-0A | DIV-02 | 02-05-0M | Protected bituminous sheet membrane waterproofing as Specification Section 07100, 50 mm thick; vertically to pile heads | 6,72 | m2 |
| P-42A-0FN-003-0A | DIV-02 | 02-05-0N | Protected bituminous sheet membrane waterproofing as Specification Section 07100, 50 mm thick; horizontally to pile heads | 1,96 | m2 |

VARIATIONS AND CLAIMS SUPPORT

VISUALIZATION FOR CHANGED AREA & AFFECTIVE WORKS

TACKLING CHANGES IN THE MODEL AND INTEGRATING THE DIFFERENT OBJECTS WITH THE VARIATION/CLAIM DOCUMENTATION (DRAWINGS, CORRESPONDENCE AND OTHER CLAIM SPECIFIC DOCUMENTS AS NEEDED)

INTEGRATE BIM WITH GIS (GEOGRAPHIC INFORMATION SYSTEM) FOR BETTER VISUALIZATION OF VARIATIONS AN CLAIMS IMPACT FOR INFRASTRUCTURES PROJECTS

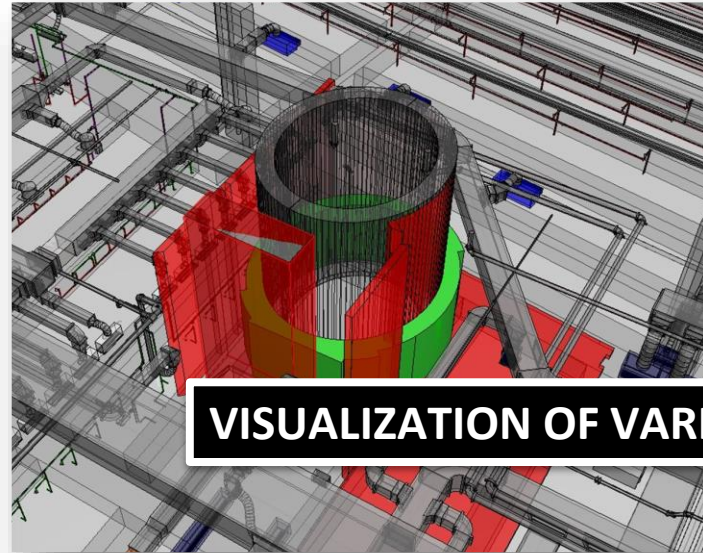

VISUALIZATION OF VARIATION IMPACT INCLUDING SCOPE

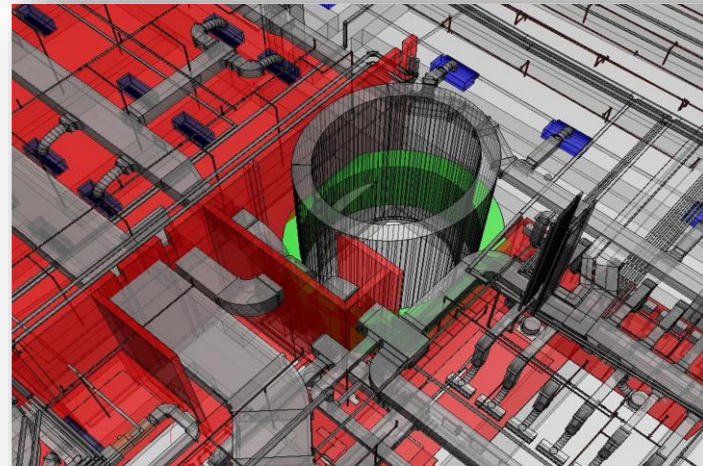

Legend:

- 0 <= Progress < 30
- 30 <= Progress < 75
- 75 <= Progress < 100
- Complete
- No Progress

| Activity ID | Activity Desc | W6_id | Object Qty | Object Progress Perc | Progress | sub sector | Project Engineer |
|--|---|-----------------------------------|------------|----------------------|----------------|------------|--------------------|
| trade | | | | | | | |
| trade desc Cable Routing , LV Cable tray | | | | | | | |
| DCPB2MDV265501010 | CABLE TRAYS & TRUNKING - PART 1 (CB.LB2,S560) | MTB_BuCP_B2_ELE-CRT_TRY-5.11D-001 | 395.6972 | 100.0 | Complete | 5.11D | ELE_Chahine Atalla |
| DCPB2MDV265501010 | CABLE TRAYS & TRUNKING - PART 1 (CB.LB2,S560) | MTB_BuCP_B2_ELE-CRT_TRY-5.12A-001 | 28.795034 | 100.0 | Complete | 5.12A | ELE_Chahine Atalla |
| DCPB2MDV265501010 | CABLE TRAYS & TRUNKING - PART 1 (CB.LB2,S560) | MTB_BuCP_B2_ELE-CRT_TRY-5.12C-001 | 466.65515 | 100.0 | Complete | 5.12C | ELE_Chahine Atalla |
| DCPB2MDV265501011 | CABLE TRAYS & TRUNKING | MTB_BuCP_B2_ELE-CRT_TRY-5.16 | 129.88898 | 88.83797 | 75 <= Progress | 5.16D | ELE_Chahine |

Page 1 of 7

INTERFACE MANAGEMENT

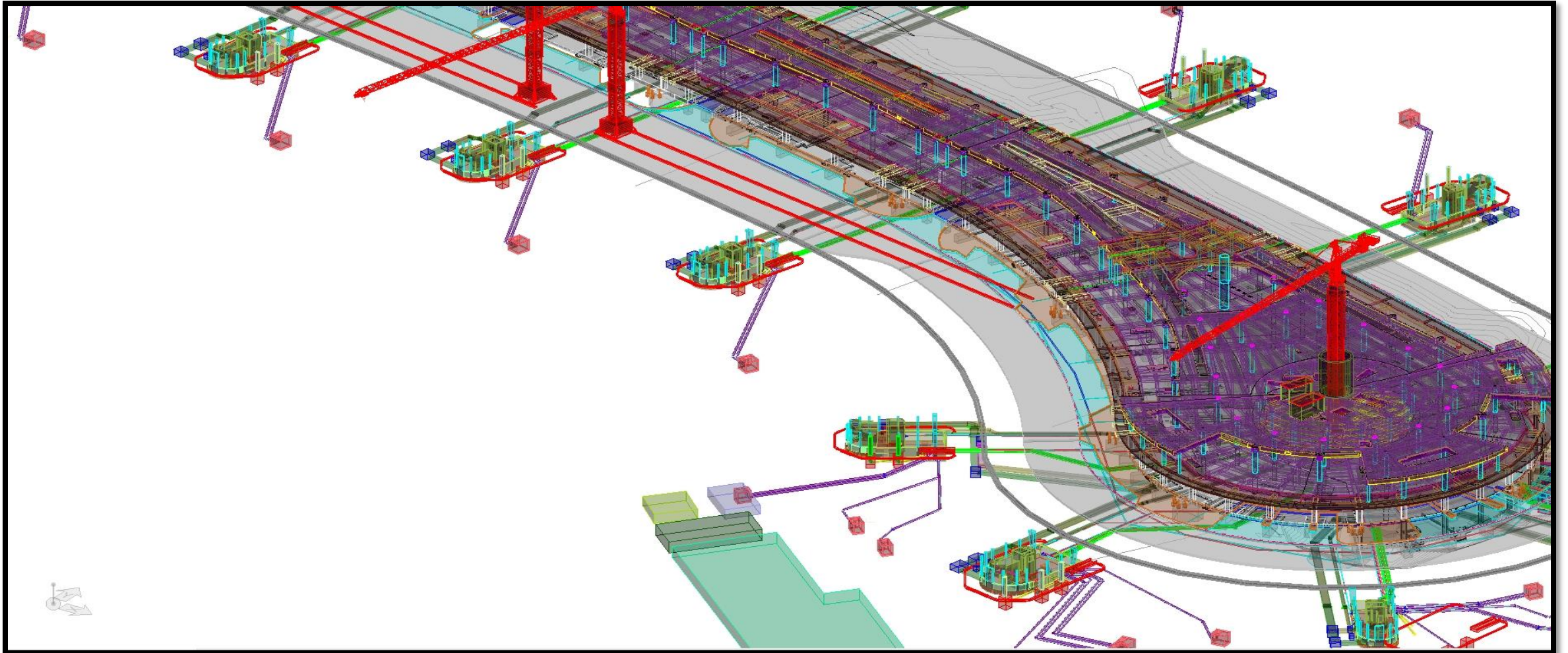



WATER, SEWAGE NETWORKS AND ASSETS DIGITAL TWINS POTENTIAL SOLUTIONS AND ADDED VALUE

BIM IS THE HEART OF MODERN TECHNOLOGIES

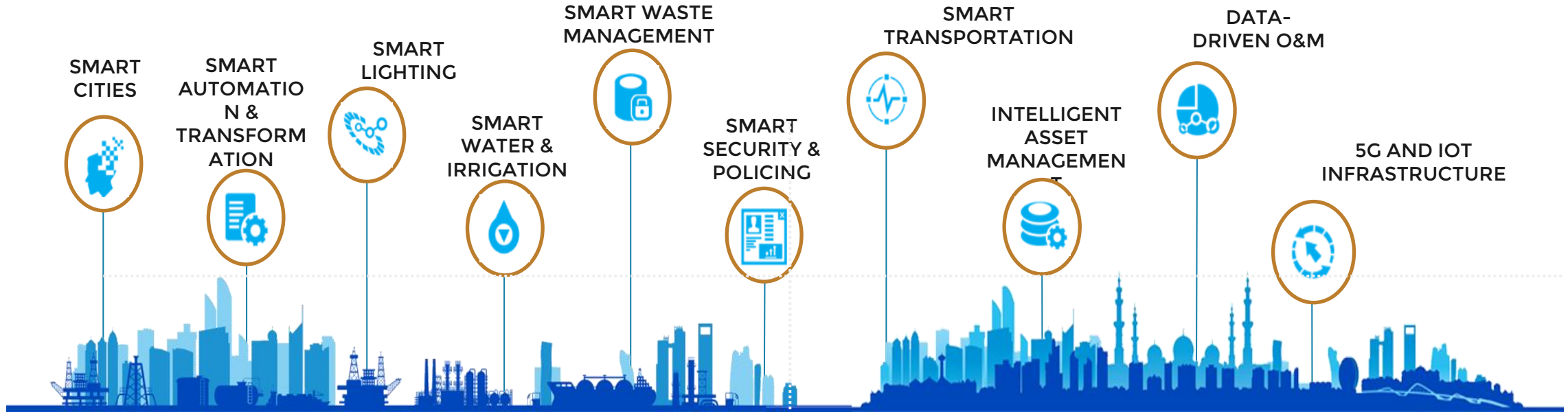

SMART SOCIETIES

SMART BUILDINGS

IoT

DIGITIZATION



POINT CLOUDS



INDUSTRY 4.0

SMART CITIES

DIGITAL CONSTRUCTION



BIM Digital Information Exchange Schema

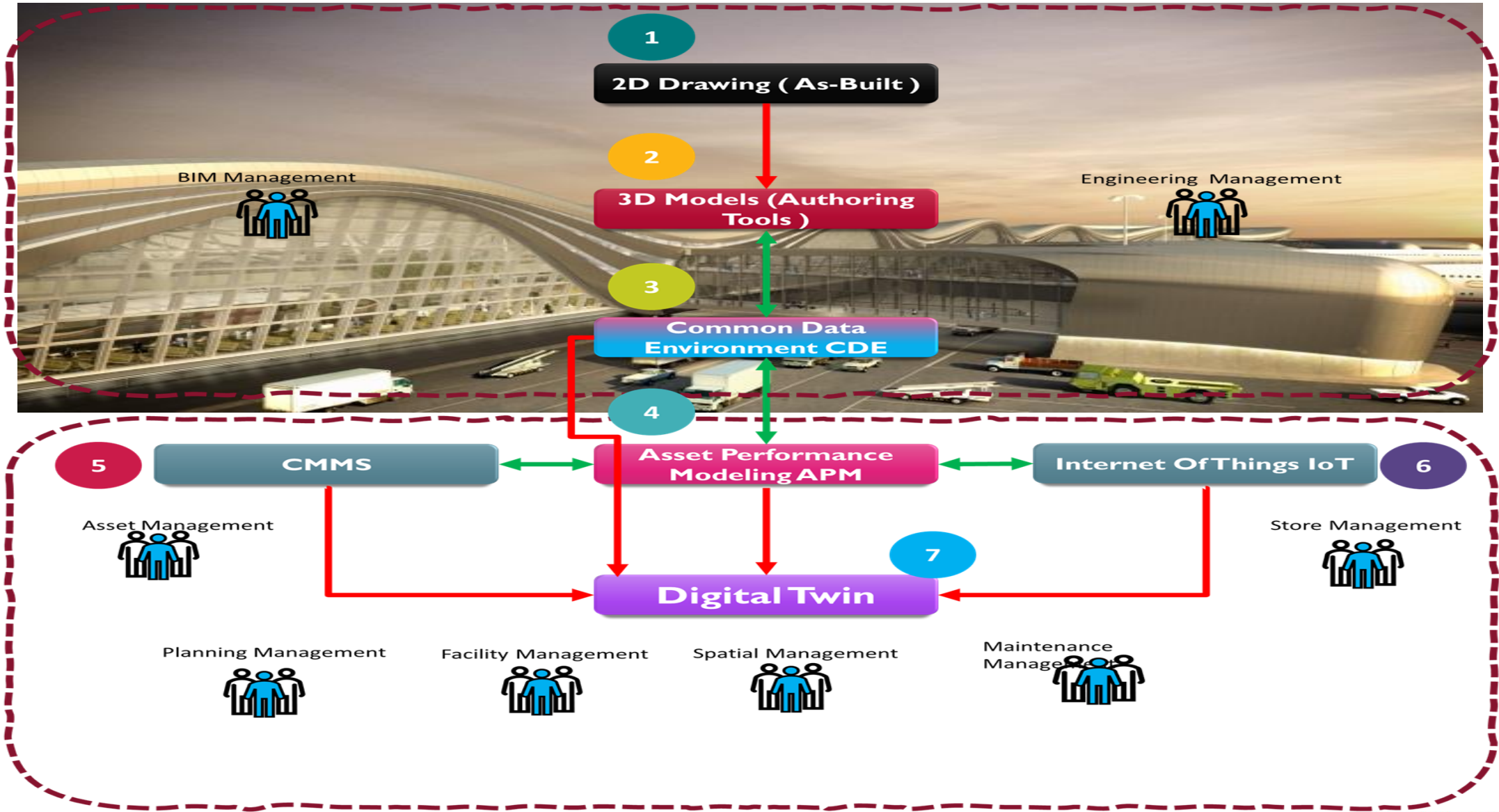

FUTURE USE-CASES FOR EYDAP'S ASSET MANAGEMENT PLANS

COBie Compliance

COBie - C3D Implementation ER Diagram

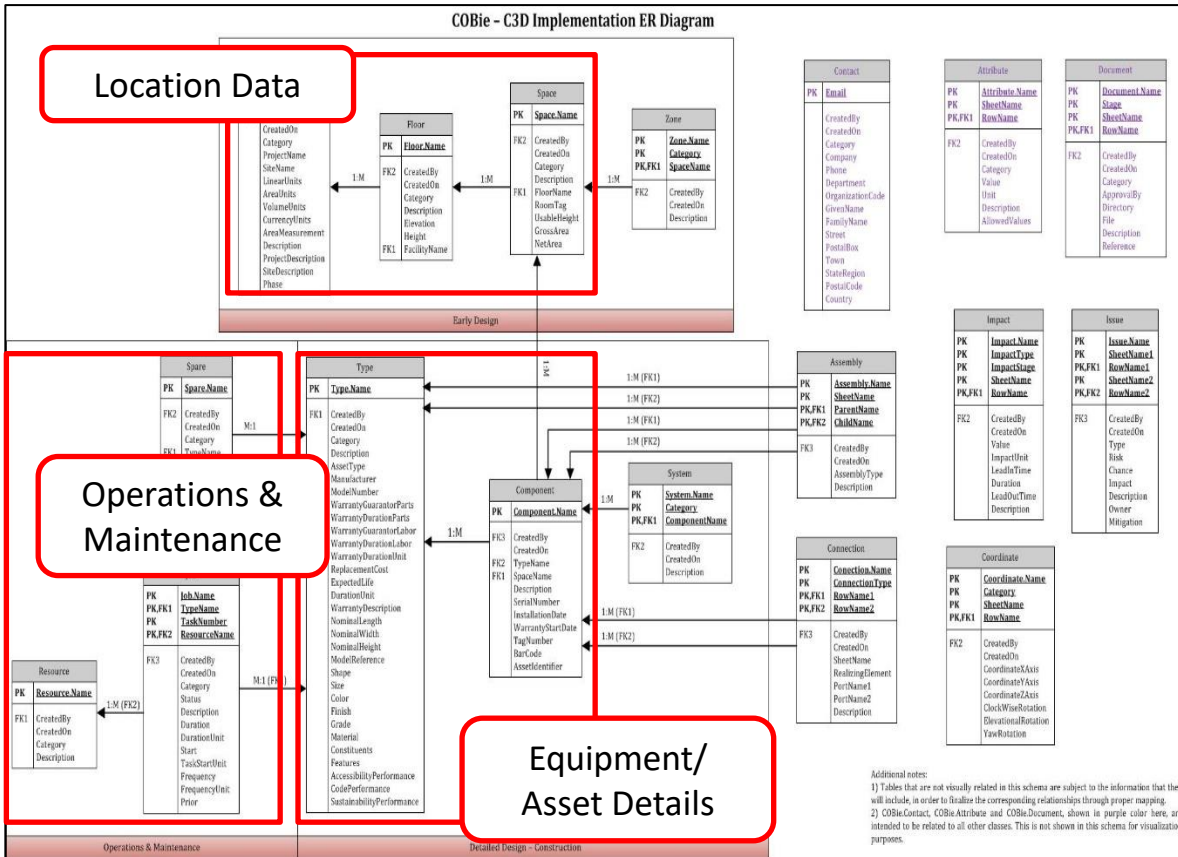

ASSET INFORMATION

The screenshot displays a 3D model of a fire extinguisher on the left and a data table on the right. The table lists various attributes and their values for the fire extinguisher.

Sample Fire Protection equipment: Fire Extinguisher

Location data: Building, Discipline, Discipline_by_floor, Discipline_by_room, Equipment_Type, Floor.

Equipment description & system part details: MTO_Component, MTO_Component Family, MTO_Description, MTO_Family, MTO_Level Name, MTO_Part, MTO_Part Description, MTO_Quantity, MTO_Unit.

Manufacturer Contact details: MemberMark, Project, Room, WBS Level 6, _modelfile.

Equipment serial number: attached_files.

Testing package code: id_description, id_manufacturer, id_model, id_serial_no_or_part_no, id_test_pack_code, id_warranty_expiry.

Warranty expiry: layer.

Please note that Warranty Expiry can only be determined once F-CO2S-EQPM layer.

FUTURE USE-CASES FOR EYDAP'S ASSET MANAGEMENT PLANS

The screenshot displays a software interface for asset management. On the left, a 'Project Explorer' pane lists numerous equipment items, each with a unique ID and name. The central area shows a 3D model of a refrigerator, with a callout box labeled 'Sample Medical equipment: Refrigerator'. To the right, an 'Object Properties' panel provides detailed information for the selected refrigerator, including its manufacturer, model, and location. A second callout box labeled 'Attainia FM data' points to the 'AttainiaFM' section of the properties panel, and a third callout box labeled 'Equipment description & system part details' points to the 'MTO' section.

Sample Medical equipment: Refrigerator

Attainia FM data

Equipment description & system part details

| AttainiaFM | |
|--------------------------------|---|
| AttainiaFM_AssetTagRFCV | 1861B-RFCV-17-0279_1 |
| AttainiaFM_AssetTagRFIT | 1861B-RFIT-17-0061_0 |
| AttainiaFM_BidGroup | 9 - ME |
| AttainiaFM_BioMedTag | ME102884 |
| AttainiaFM_COC_HO_DocumentDate | 2/14/2016 |
| AttainiaFM_Department | Research Lab - C5 |
| AttainiaFM_Description | Refrigerator Laboratory Undercounter |
| AttainiaFM_FI | O/O |
| AttainiaFM_ItemGroup | Group 1 |
| AttainiaFM_ItemID | 4239-013 |
| AttainiaFM_ItemNotes | Original location Unassigned equipment room moved a |
| AttainiaFM_ItemQTY | 1 |
| AttainiaFM_ItemRef | n/a |
| AttainiaFM_Manufacturer | Thermo Fisher Scientific |
| AttainiaFM_Medical | Medical |
| AttainiaFM_Model | FORMA LAB REF UP 133LPLUS |
| AttainiaFM_OptionBioMedTag | n/a |
| AttainiaFM_OptionDescription | n/a |
| AttainiaFM_OptionQTY | 1 |
| AttainiaFM_OptionSerial | n/a |
| AttainiaFM_RoomNo | C5-73143 |
| AttainiaFM_Serial | 0 112427001130225 |
| AttainiaFM_Status | In Use |
| AttainiaFM_Training | 2/12/2016 |
| AttainiaFM_WFRoomName | Lab- 05 Lab- 05 |

| MTO | |
|----------------------|--|
| MTO_Component | E2030-1.08 |
| MTO_Component Family | E2032-1.08.015 |
| MTO_Description | Refrigerator Laboratory Undercounter |
| MTO_Level Name | SMRC_OPC_ME |
| MTO_Part | OPC_4239-013 |
| MTO_Part Description | Refrigerator, Laboratory, Undercounter |
| MTO_Quantity | |
| MTO_Unit | pc |

BIM INTEGRATION WITH IoT ASSETS PERFORMANCE AND LIFECYCLE MANAGEMENT

The screenshot displays a BIM software interface with a 3D model of a building. Overlaid on this is the 'SenseOne' IoT monitoring dashboard. The dashboard features the 'AIDIGITS' logo and 'Assets Monitoring' title. It includes a navigation menu with 'Site Views', 'Assets Tree', 'Information', 'History', and 'Chart'. The 'Assets Tree' shows a hierarchy for 'CCC Office' with sub-items like 'Main Electricity Panel', 'Office', 'FanCoil1', 'FanCoil2', 'LightsT5', 'Sensors', 'Temperature', 'CO2', 'Illuminance', 'Motion Detector', 'Window Contact 7', 'Door', and 'TrainingRoom532'. The 'Chart' section shows a line graph for '02 May 2017' with 'Average: 28,81 °C' for 'oc Temperature (°C)'. The background BIM interface shows a 'Project Explorer' with a tree structure including 'Classes', 'Component', 'Model', 'EventSites', 'EventSites_CV', 'EventMap', 'Sensors (Sensors_EventSite)', 'EventSitesUpdates', 'family', 'part', 'Room', 'Sensors', 'part (part_Sensors)', 'Sensors_Properties', and 'part (Sensors_to_part)'. A 'Sensors_Properties' table is visible at the bottom left with columns 'id' and 'parent_id', containing the row '17677' and '17594'. A notification bar at the bottom shows 'High Office Temperature' with ID '151' and 'Notification' with ID '17677'. The SenseOne interface also shows a 'Volume' field and 'senseone v1.3.0 (#95)' version information.

INFRASTRUCTURES DIGITIZATION BIM TO SMART CITIES – SOCIETY / PUBLIC ASSETS

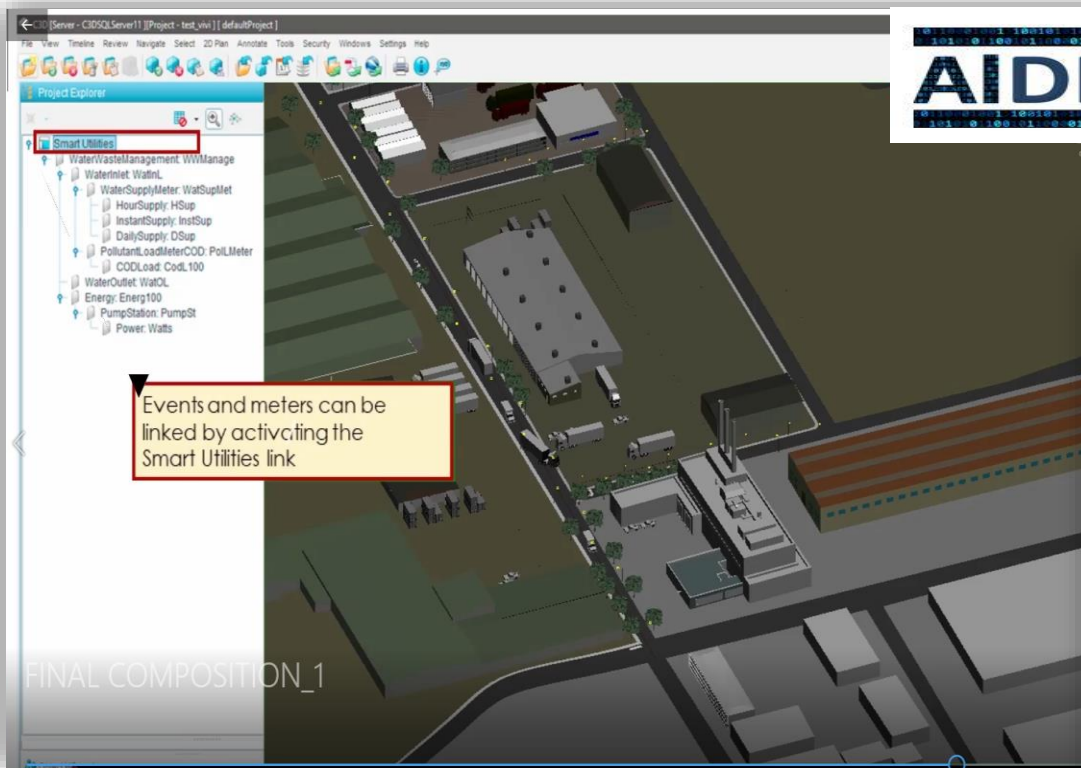

AIDIGITS

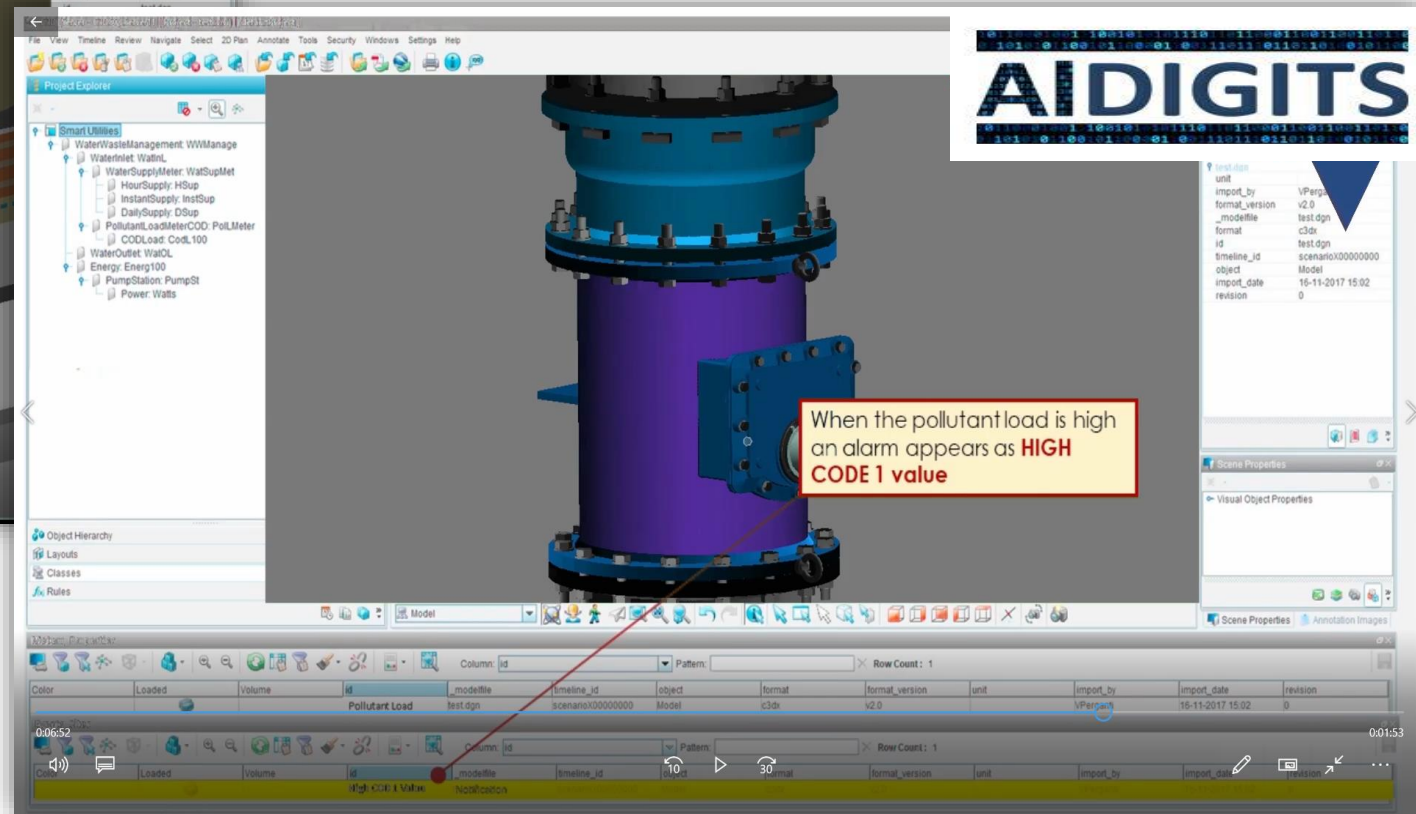

AIDIGITS

BIM BASED FM DASHBOARDS

